

This bulletin also applies to RCA-23FBP4 which is identical with RCA-23ENP4 except for its faceplate which is treated to reduce specular reflection.



from JEDEC release
#4649, March 30, 1964

RCA-23ENP4

PAN-O-PLY

PICTURE TUBE

Initial Data

RCA-23ENP4 is a black-and-white pan-o-ply picture tube which eliminates the need for either an integral protective window or a separate safety-glass window and its companion dust seal in the receiver. As a result internal reflections are reduced, and picture contrast is improved. Integral implosion protection in the pan-o-ply picture tube is provided by means of a formed rim band and a welded tension band around the periphery of the tube panel. The 23ENP4 is a rectangular glass picture tube having an aluminized screen with nearly straight sides and slightly rounded corners.

Features of the 23ENP4 include:

- PAN-O-PLY—Integral Implosion Protection
- 92° Magnetic Deflection
- Low-Voltage Electrostatic Focus
- Aluminized Screen
- Electron Gun Requiring No Ion-Trap Magnet
- 18.500" Max. Overall Length
- 5.625" Neck Length
- 15.125" x 19.250" Screen
- 6.3 Volt/600 Ma Heater
- Low Grid-No.2 Voltage—
For Cathode-Drive Service
- 25 kv Max. Anode Voltage

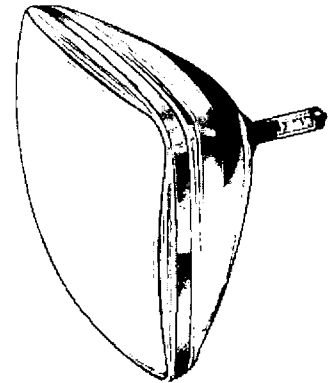

GENERAL DATA

Electrical:

Focusing Method Electrostatic
Deflection Method Magnetic
Deflection Angles (Approx.):

Diagonal 92°
Horizontal 80°
Vertical 65°

Direct Interelectrode Capacitances:

Cathode to all other electrodes 5 pf
Grid No.1 to all other electrodes 6 pf
External conductive coating
to anode^a { 2500 max. pf
1700 min. pf

Heater Current at 6.3 volts 600 ± 30 ma
Heater Warm-Up Time (Average) 11 seconds

Heater warm-up time is defined as the time required in the test circuit shown in Fig.1 for the voltage (E) across the heater terminals to increase from zero to 0.8 of rated heater voltage.

Electron Gun Type Requiring No Ion-Trap Magnet

Optical:

Phosphor P4—Sulfide Type, Aluminized
Faceplate Filterglass
Light transmission at center (Approx.) 42%

Mechanical:

Weight (Approx.) 29 lbs

Tube Dimensions:

Overall length 18.125" ± .375"
Neck length 5.625" ± .188"
Diagonal 23.500" ± .125"
Greatest width 20.650" ± .125"
Greatest height 16.650" ± .125"

Minimum Screen Dimensions (Projected):

Diagonal 22.312"
Greatest width 19.250"
Greatest height 15.125"
Area 282 sq. in.

Bulb Designation J187 J
Cap Designation Recessed Small Cavity
(JEDEC No. J1-21)

Base Designation Short Small-Shell Duodecal
6-Pin, (JEDEC Group 4, No. B6-203)

Basing Designation 12L

- Pin 1: Heater
- Pin 2: Grid No.1
- Pin 6: Grid No.4
- Pin 10: Grid No.2
- Pin 11: Cathode
- Pin 12: Heater

Cap: Anode (Grid No.3,
Grid No.5, Screen,
Collector)

C: External Conductive
Coating

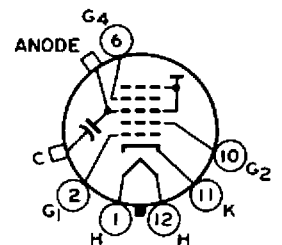

BOTTOM VIEW

Maximum and Minimum Ratings, Design-Maximum Values:^b

Unless otherwise specified, voltage values are positive with respect to grid No.1

Anode Voltage	$\left\{ \begin{array}{l} 25,000 \text{ max.} \\ 11,000 \text{ min.} \end{array} \right.$	volts
Grid-No.4 Voltage:		
Positive value.	1250 max.	volts
Negative value.	400 max.	volts
Grid-No.2 Voltage	$\left\{ \begin{array}{l} 70 \text{ max.} \\ 40 \text{ min.} \end{array} \right.$	volts
Cathode Voltage:		
Negative peak value	2 max.	volts
Negative bias value	0 max.	volts
Positive bias value	100 max.	volts
Positive peak value	150 max.	volts
Heater Voltage ^c	$\left\{ \begin{array}{l} 6.9 \text{ max.} \\ 5.7 \text{ min.} \end{array} \right.$	volts
Peak Heater-Cathode Voltage:		
Heater negative with respect to cathode:		
During equipment warm-up period not exceeding 15 seconds.	450 max.	volts
After equipment warm-up period.	300 max.	volts
Heater positive with respect to cathode:		
Combined AC & DC voltage.	200 max.	volts
DC Component.	100 max.	volts

Typical Operating Conditions for Cathode-Drive^d Service:

Unless otherwise specified, voltage values are positive with respect to grid No.1

Anode Voltage	20,000	volts
Grid-No.4 Voltage ^e	200	volts
Grid-No.2 Voltage	50	volts
Cathode Voltage for visual extinction of focused raster (See Fig.2).	36 to 54	volts
Field Strength of required adjustable Centering Magnet ^f	0 to 12	gauss

Maximum Circuit Value:

Grid-No.1 Circuit Resistance.	1.5 max.	megohms
---------------------------------------	----------	---------

^a Includes implosion protection hardware.

^b The maximum ratings in the tabulated data are established in accordance with the following definition of the Design-Maximum Rating System for rating electron tubes.

Design-Maximum ratings are limiting values of operating and environmental conditions applicable to a bogey electron device of a specified type as defined by its published data, and should not be exceeded under the worst probable conditions.

The device manufacturer chooses these values to provide acceptable serviceability of the device, taking responsibility for the effects of changes in operating conditions due to variations in device characteristics.

The equipment manufacturer should design so that initially and throughout life no Design-Maximum value for the intended service is exceeded with a bogey

device under the worst probable operating conditions with respect to supply-voltage variation, equipment component variation, equipment control adjustment, load variation, signal variation, and environmental conditions.

^c Measured between the heater terminals.

^d Cathode drive is the operating condition in which the video signal varies the cathode potential with respect to grid No.1 and the other electrodes.

^e The grid-No.4 voltage required for optimum focus of any individual tube will have a value anywhere between 0 and +400 volts with the combined grid-No.1 voltage and video-signal voltage adjusted to give an anode current of 200 microamperes on a 13-1/2-inch by 18-inch pattern from an RCA-2F21 monoscope, or equivalent.

^f Distance from Reference Line for suitable PM centering magnet should not exceed 2-1/4 inches. The specified centering magnet compensates only for the effect which mechanical tube tolerances may have on the location of the undeflected, focused spot with respect to the center of the tube face. Maximum field strength of adjustable centering magnet equals

$$\sqrt{\frac{\text{Anode volts}}{16000 \text{ volts}}} \times 10 \text{ gauss}$$

The equipment manufacturer must determine and supply additional compensation for the effects of the earth's magnetic field and extraneous fields due to choice of circuitry and components. The additional compensation should preferably be applied as part of the magnetic field of the deflecting yoke.

OPERATING CONSIDERATIONS

X-Radiation Warning. When operated at anode voltages up to 16 kilovolts, this picture tube does not produce any harmful X-radiation. However, because the rating of this type permits operation at voltages as high as 25 kilovolts (design-maximum value), shielding of the tube for X-radiation may be needed to protect against possible injury from prolonged exposure at close range whenever the operating conditions involve voltages in excess of 16 kilovolts.

TEST CIRCUIT FOR DETERMINING HEATER WARM-UP TIME

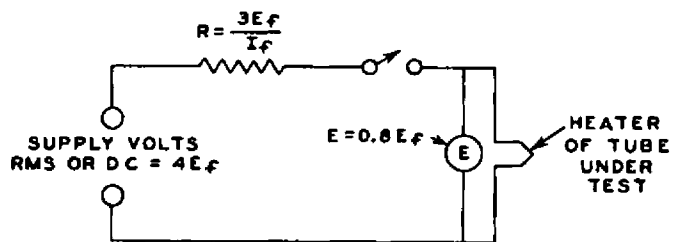

E_f = RATED HEATER VOLTAGE OF TUBE UNDER TEST.
 I_f = RATED HEATER CURRENT OF TUBE UNDER TEST.
 92CS-8503

Fig.1

Information furnished by RCA is believed to be accurate and reliable. However, no responsibility is assumed by RCA for its use; nor for any infringements of patents or other rights of third parties which may result from its use. No license is granted by implication or otherwise under any patent or patent rights of RCA.

RASTER CUTOFF CHART
For Cathode-Drive Service

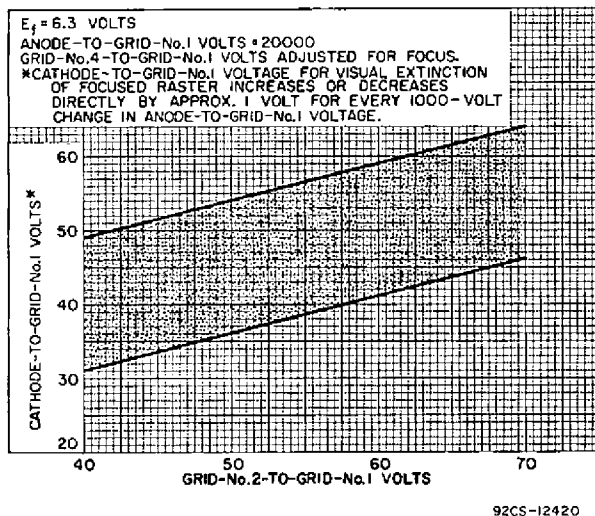
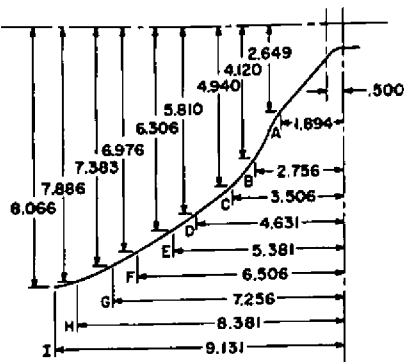

Fig.2

BULB-CONTOUR DIMENSIONS

SHORT-SIDE VIEW



LONG-SIDE VIEW

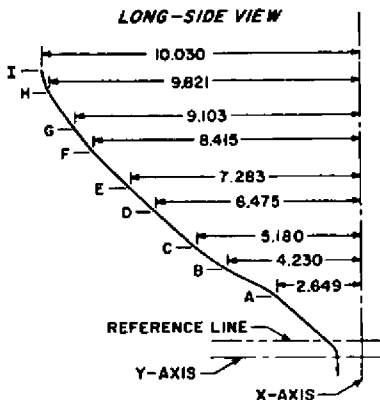

DIAGONAL VIEW

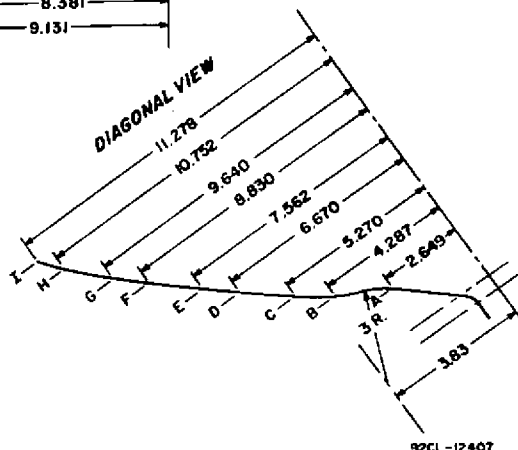

PLANES A THROUGH I ARE NORMAL TO THE TUBE AXIS AND AT FIXED LOCATIONS FROM THE Y AXIS. THESE COORDINATES DESCRIBE THE BOGIE BULB EXTERNAL CONTOUR IN PLANES THROUGH THE TUBE AXIS AND THE RESPECTIVE FACEPLATE AXES.

DIMENSIONAL OUTLINE

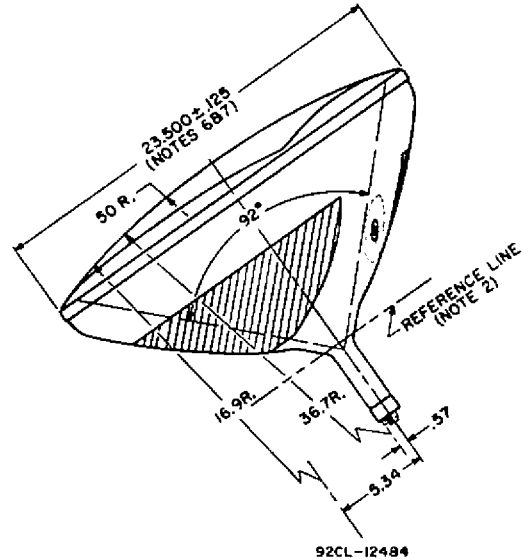
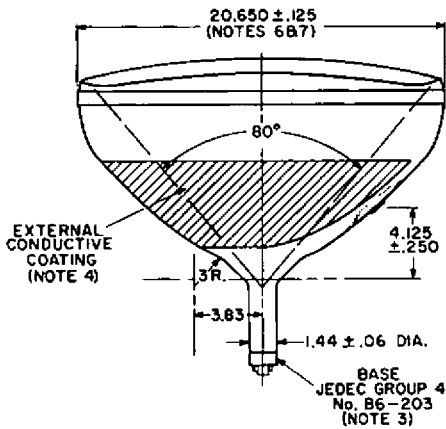
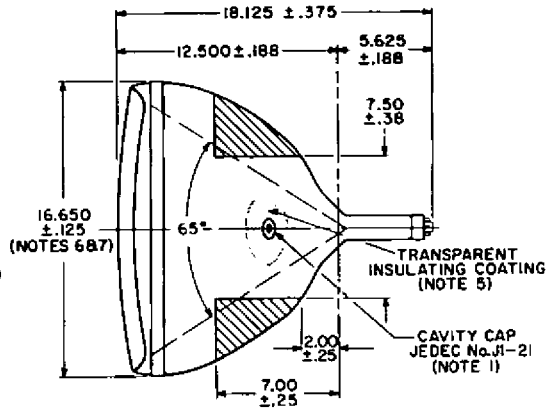
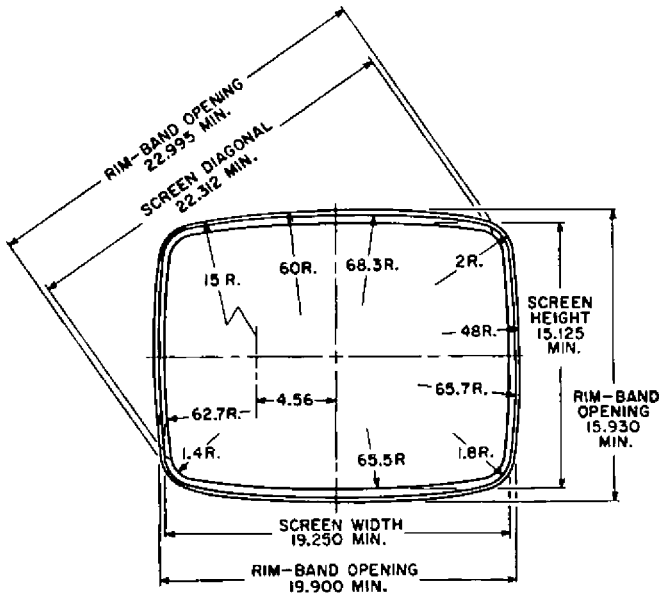

DETAIL OF PANEL (Diagonal View)

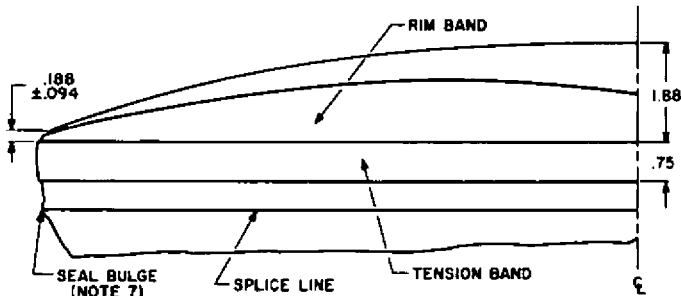

DIMENSIONS IN INCHES

NOTE 1: THE PLANE THROUGH THE TUBE AXIS AND PIN No. 6 MAY VARY FROM THE PLANE THROUGH THE TUBE AXIS AND ANODE TERMINAL BY ANGULAR TOLERANCE (MEASURED ABOUT THE TUBE AXIS) OF ±30°. ANODE TERMINAL IS ON SAME SIDE AS PIN No. 6.

NOTE 2: WITH TUBE NECK INSERTED THROUGH FLARED END OF REFERENCE-LINE GAUGE JEDEC No. G-116 AND WITH TUBE SEATED IN GAUGE, THE REFERENCE LINE IS DETERMINED BY THE INTERSECTION OF THE PLANE CC' OF THE GAUGE WITH THE GLASS FUNNEL.

NOTE 3: SOCKET FOR THIS BASE SHOULD NOT BE RIGIDLY MOUNTED; IT SHOULD HAVE FLEXIBLE LEADS AND BE ALLOWED TO MOVE FREELY. BOTTOM CIRCUMFERENCE OF BASE WAFER WILL FALL WITHIN A CIRCLE CONCENTRIC WITH BULB AXIS AND HAVING A DIAMETER OF 2-3/4".

NOTE 4: EXTERNAL CONDUCTIVE COATING AND IMPLOSION PROTECTION HARDWARE MUST BE GROUNDED.

NOTE 5: TO CLEAN THIS AREA, WIPE ONLY WITH SOFT DRY LINTLESS CLOTH.

NOTE 6: MEASURED FROM THE TENSION BAND.

NOTE 7: BULGE AT SPLICE-LINE SEAL MAY INCREASE THE INDICATED MAXIMUM VALUE FOR ENVELOPE WIDTH, DIAGONAL, AND HEIGHT BY NOT MORE THAN 1/8".