

SPECIFICATION: MOS/CV. 4509 Issue No. 1 Dated 15.7.58 To be read in conjunction with K.1001, BS.448 and BS.1409.	<u>SECURITY</u>	
	<u>SPECIFICATION</u> Unclassified	<u>VALVE</u> Unclassified

TYPE OF VALVE:- Reliable Micro-Miniature Triode with Flying Leads. CATHODE:- Directly Heated. ENVELOPE:- Metal Case. PROTOTYPE:- F3A1.		<u>MARKING</u> See K.1001/4 CV. No., T.A. Letters Factory and Date Code only required.													
<u>RATINGS</u> (All limiting ratings are absolute.)		<u>BASE</u> See drawing on page 6, Fig.1.													
Filament Voltage (V) 0.9 Filament Current (mA) 90 Max. Anode Voltage (Ia = 0) (V) 250 Max. Anode Dissipation (25°C) (mW) 200 Max. Anode Dissipation (150°C) (mW) 150 Max. Anode Temperature (°C) 150 Max. Acceleration (Continuous Operation) (g) 20 Max. Shock (short duration) (g) 500		NOTES B B	<u>CONNECTIONS</u> <table border="1"> <thead> <tr> <th>Lead No.</th> <th>Electrode</th> </tr> </thead> <tbody> <tr> <td>1</td> <td>Grid g</td> </tr> <tr> <td>2</td> <td>Filament f</td> </tr> <tr> <td>3</td> <td>Filament f</td> </tr> <tr> <td>4</td> <td>Grid g</td> </tr> <tr> <td>Case</td> <td>Anode a</td> </tr> </tbody> </table> NOTE A	Lead No.	Electrode	1	Grid g	2	Filament f	3	Filament f	4	Grid g	Case	Anode a
Lead No.	Electrode														
1	Grid g														
2	Filament f														
3	Filament f														
4	Grid g														
Case	Anode a														
<u>TYPICAL OPERATING CONDITIONS</u> Anode Voltage (V) 160 Negative Grid Voltage (V) 0.5 Mutual Conductance (mA/V) 0.4 Anode Impedance (KΩ) 110			<u>DIMENSIONS</u> See drawing on page 6, Fig.1. <u>MOUNTING POSITION</u> Any.												
<u>CAPACITANCES (pF)</u>															
Cag (nom.) 1.75 Caf (nom.) 0.7 Cfg (nom.) 0.5															
<u>NOTES</u>															
A. Soldered connection to be made to top of can only. B. To achieve this dissipation the valve requires to be run into grid current when changes in contact potential may occur.															

TESTS

C.V.4509

To be performed in addition to those applicable in K.1001.

The tests shall be performed in the specified order unless otherwise agreed with the Inspecting Authority.

TEST CONDITIONS:- Unless otherwise specified.

Vf = 0.9V.

Va = 150V.

Vg = -0.5V.

K.1001 REF.	TEST	TEST CONDITIONS	AQL %	INSP LEVEL	SYM- BOL	LIMITS					UNITS	
						MIN.	LAL	BOGEY	UAL	MAX.		AID
	<u>GROUP A</u>											
	Visual Inspection	No voltages Notes 1, 2.	-	100%	-	-	-	-	-	-	-	-
	Inoperatives Electrode	Va-all = -500V.	-	100%	R	10000	-	-	-	-	-	MR
	Insulation	Vg-all = -100V.	-	100%	R	10000	-	-	-	-	-	MΩ
	Reverse Grid Current (1)	Rg = 500KΩ max.	-	100%	-I _{g1}	-	-	-	-	0.05	-	μA
	Voltage Gain	Va(b) = 150V. RL = 270KΩ Rg = 1MΩ Note 3.	-	100%		27	-	28.5	-	30	-	db
	<u>GROUP B</u>											
	Filement Current		0.4	II	If	85	-	90	-	95	-	mA
	Anode Current (1)		0.4	II	Ia	500	-	700	-	900	-	μA
				V2	Ia	To be recorded and agreed later.					μA	
	Mitual Conductance		0.4	II	gm	300	-	400	-	500	-	μA/V
				V2	gm	To be recorded and agreed later.					μA/V	
	<u>GROUP C</u>											
	Anode Current (2)	Vg = -3.5V.	2.5	I	Ia (tail)	-	-	-	-	50	-	μA
5.12	Lead Fragility	No voltages	2.5	I	-	-	-	-	-	-	-	-
	Change of Mutual Conductance	Vf = 0.8V. Note 7.	2.5	I	Δgm	-	-	-	-	15	-	%
	Reverse Grid Current (2)	Vf = 1.0V. Adjust Vg for Ia = 1.0 mA. Notes 7 and 8.	2.5	I	-I _{g1}	-	-	-	-	0.1	-	μA

CV.4509

K.1001 REF.	TEST	TEST CONDITIONS	AQL %	INSP LEVEL	SYM- BOL	LIMITS					UNITS	
						MIN.	LAL	BOGEY	UAL	MAX.		AID
11.3	<u>GROUP E</u>											
	Fatigue	Vf = 0.9V. Min. Acceleration = 20g. Freq. = 170cps Duration = 100 hours. Note 4.	-	I	-	-	-	-	-	-	-	
	<u>POST FATIGUE TESTS</u>	Combined AQL = 2.5%										
	Reverse Grid Current (1)	As in Group A.	1.0	-	-I _{g1}	-	-	-	-	0.05	-	μA
	Mutual Conductance		1.0	-	gm	300	-	400	-	500	-	μA/V
	SHOCK	Min. deceleration = 5000g. No voltages. Note 9.	-	I	-	-	-	-	-	-	-	-
	<u>POST SHOCK TESTS</u>	Combined AQL = 2.5%										
Reverse Grid Current (1)	As in Group A.	1.0	-	-I _{g1}	-	-	-	-	0.05	-	μA	
Mutual Conductance		1.0	-	gm	300	-	400	-	500	-	μA/V	
AVI/ 5	<u>GROUP F</u>											
	Life	Note 5.										
	AVI/ 5.1	<u>Stability Life</u>	(1 hour)									
	Change in Mutual Conductance		1.0	I	Agm	-	-	-	-	10	-	%
	AVI/ 5.3	<u>Intermittent Life</u>										
	Test Point 500 hours.	Combined AQL	4.0	IA	-	-	-	-	-	-	-	-
	AVI/ 5.6	Inoperatives Filament Current		2.5	-	-	-	-	-	-	-	-
Reverse Grid Current (1)	As in Group A.	2.5	-	If	85	-	90	-	95	-	mA	
Mutual Conductance		2.5	-	-I _{g1}	-	-	-	-	0.05	-	μA	
Average Change of Mutual Conductance		2.5	-	gm	260	-	-	-	500	-	μA/V	
Electrode Insulation	Va-all = -500V. Vg-all = -100V.	2.5	-	R	10000	-	-	-	-	-	MΩ	
			-	R	10000	-	-	-	-	-	MΩ	

K.100 REF.	TEST	TEST CONDITIONS	AQL %	INSP LEVEL	SYM- BOL	LIMITS						UNITS
						MIN.	LAL	BOGEY	UAL	MAX.	AID	
	<u>GROUP F (contd.)</u>											
	Test Point 1000 hours. Combined AQL		6.5	IA								
AVI/ 5.6	Inoperatives Filament Current	As in Group A.	4.0	-	-	-	-	-	-	-	-	-
	Reverse Grid Current (1)		4.0	-	If	85	-	90	-	95	-	mA
			4.0	-	-Igt	-	-	-	-	0.05	-	μA
	Mutual Conductance		4.0	-	gm	240	-	-	-	500	-	μA/V
	Electrode Insulation	Va-all = -500V. Vg-all = -100V.	4.0	-	R	10000	-	-	-	-	-	MΩ
			-	-	R	10000	-	-	-	-	-	MΩ
	<u>GROUP G</u>											
AIX/ 2.5	Electrical Retest after 28 days holding period.			100%	-	-	-	-	-	-	-	-
AVI/ 5.6	Inoperatives Reverse Grid Current (1)	As in Group A.	0.5	-	-	-	-	-	-	0.05	-	μA
			0.5	-	-Igt	-	-	-	-	-	-	μA
	<u>GROUP H</u>											
AIII	Capacitances	Measured on a 1Mc/s bridge. Valve mounted in an approved fully shielded socket. Note 6.		T.A.	Cag Caf Cf g	1.6 0.66 0.47	- - -	1.75 0.7 0.5	- - -	1.9 0.74 0.54	- - -	PF PF PF

NOTES

1. The valve shall be visibly inspected for good workmanship.
2. This test may be carried out in Group C.
3. A typical circuit for the measurement of voltage gain is shown on page 6, Figure 2.
4. The valves shall be vibrated in each of the three required planes for a total period of not less than 100 hours (30 + 39 + 30). Filament switched one minutes on, three minutes off. No other voltages applied.

NOTES
(contd.)

5. The Life Test conditions are : -

The Life Tests to be carried out in an Ambient Temperature of 150°C and
Vg = -1.5V. Va adj. for Wa = 100mW. (Ia = 0.6mA approx.)

6. Capacitance connections to be made as follows:-

TEST	NP	LP	E
Ceg	Can	1, 4	2, 3
Caf	Can	2, 3	1, 4
Cfg	2, 3	1, 4	Can

7. Prior to this test the valve shall be pre-heated for not less than five minutes under the test conditions.
8. Grid current shall not be rising or out of limit after a total time of ten minutes (including pre-heating time).
9. This test to be carried out using a lead block decelerator. Direction of shock to be applied along the longitudinal axis.

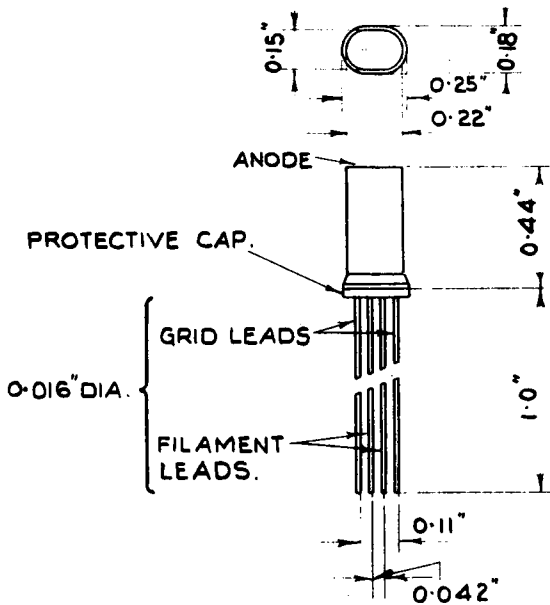

FIG.1. OUTLINE DRAWING.

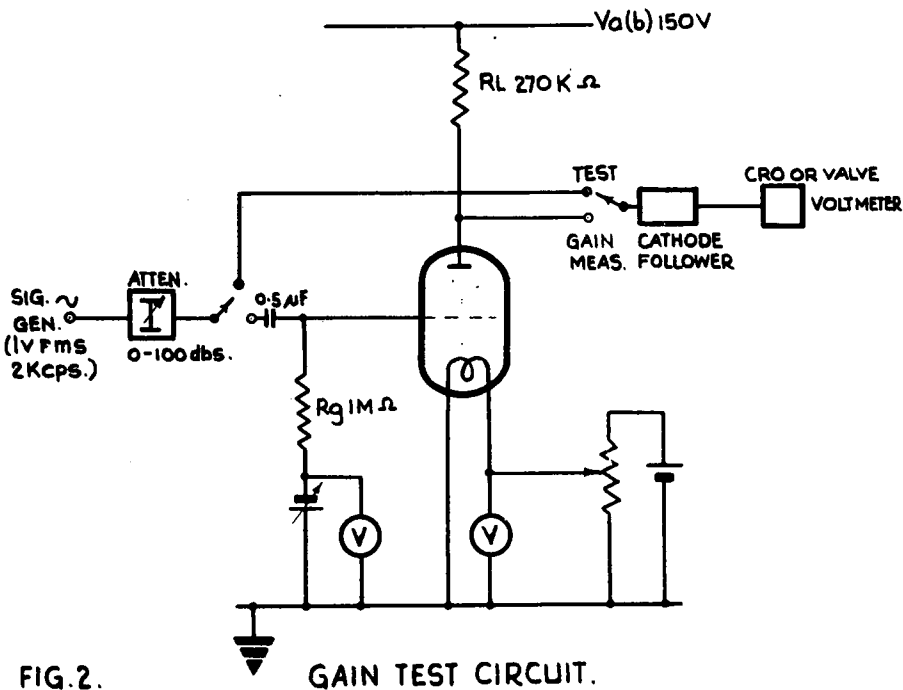

FIG.2. GAIN TEST CIRCUIT.