

Specification MOS/CV 2422 Issue 1 dated 24.6.57 To be read in conjunction with K1001, BS1409 and BS448		<u>Security</u> <u>Specification</u> <u>Valve</u> Unclassified Unclassified	
<u>Type of Valve</u>	Velocity-modulated coaxial line oscillator with external cavity resonator	<u>Marking</u> See K1001/4	
<u>Cathode</u>	Indirectly heated		
<u>Envelope</u>	Glass		
<u>Prototype</u>	VX 7104		
<u>Rating</u>		<u>Note</u>	<u>Base</u> BS448/B7G
Heater voltage (V)	6.3 +5%	A	<u>Connections</u>
Heater current (Nom.) (A)	0.26	A	<u>Pin</u> <u>Electrode</u>
Grid voltage Vg1 (V)	-30 to -50		1 Grid g1
Resonator voltage VRes (V)	312 +3%	B	2 Cathode k
Screen voltage Vg2 (V)	75 to 350 Nom. 125	C	3 Heater h
Anode voltage Va (V)	VRes+10 to VRes+20	D	4 Heater h
Power output (min.) (W)	0.3	E	5 Anode a
Mechanical Tuning range (min.) (cms)	6.2 to 6.8		6 Resonator Res
Electronic Tuning range (min.) (Mc/s)	3		7 Screen grid g2
Magnetic Field (min.) (Oersteds)	1,300	F	<u>Dimensions</u>
Maximum resonator dissipation (W)	10		See drawing, page 4
Maximum anode dissipation (W)	15		
Maximum cathode current (mA)	100		
Maximum bulb temperature (opposite anode) (°C)	280		

NOTES

- A. A.C. frequencies above 65 c/s must not be used.
 B. At $\lambda = 6.5$ cms. At other frequencies V_{Res} varies as f^2 .
 C. Varied to maintain I_k constant.
 D. Operation with $V_a = V_{Res}$ may result in increased noise in the output.
 E. Within range 6.2 to 6.8 cms.
 F. With Jessops magnet type 9501, Alcomax III, minimum flux 1300 Oersteds.
 G. All voltages are quoted with respect to cathode, (Heater voltage excepted.)

TESTS

To be performed in addition to those applicable in K.1001

	Test Conditions						Test	Limits		No. Tested	Notes
	V _h (V)	V _{g1} (V)	I _k (mA)	V _{g2} (V)	V _{Res} (V)	λ (cms)		Min.	Max.		
a	6.3	-	-	-	-	-	I _h (A)	0.22	0.30	100%	
b	6.3	-40	50	Adjust	312	-	V _{g2} (V)	90	200	100%	1
c	6.3	-40	50	Value found in Test 'b'	350	-	I _{g2} (mA)	-	4	100%	1
d	6.3	-40	50	Adjust	280 to 305	6.8	(1) Power output (mW) (2) Electronic tuning range between half power points (Mc/s)	300 3	- -	100% 100%	1,2,3 1,5
e	6.3	-40	50	As in Test 'd' (1)	As in Test 'd' (1) with 20V peak to peak A.C. superimposed	6.8	Frequency deviation (Mc/s peak to peak)	2.0	3.2	50%	1,4
f	6.3	-40	50	Adjust	335 to 365	6.2	(1) Power output (mW) (2) Electronic tuning range between half power points (Mc/s)	300 3	- -	100% 100%	1,2,3 1,5
g	6.3	-40	50	As in Test 'f' (1)	As in Test 'f' (1) with 20V peak to peak A.C. superimposed	6.2	Frequency deviation (Mc/s peak to peak)	2.6	4.0	50%	1,4
h	6.3	-40	50	Adjust	330	-	Life Test (1) Life Test End Point (100 hrs.)	-	-	Note 8	1,6
j	6.3	-40	50	Continuously adjusted throughout test.	330	-	Life Test (2) Life Test End Point (4,300 hrs. min.)	-	-		1,7

NOTES

1. With V_a at $V_{Res} + 15$ volts and a magnetic field of 1,500 Oersteds maximum.
2. The valve to be operated in an approved circuit consisting of 2" x 1" waveguide (WG12) with the valve mounted in the centre of the broad face. On one side of the valve there is a fixed short circuit 2.5 cms. from valve centre line, and on the other side, a tuning plunger. An output loop coupling is situated in line with the valve in the centre of the narrow face, and the loop adjusted by insertion and rotation for maximum power output.
3. V_{Res} to be adjusted for maximum power output.
4. The resonator to be earthed, and capacitors of low impedance at modulation frequency to be connected between grid and cathode, and screen and cathode. The modulation to be applied between cathode and resonator.
5. The resonator voltage to be varied above and below the value found in test (1), until the power falls to half the value obtained in test (1).
6. A valve is considered to have failed if V_{g2} increases by more than 20% during the test, I_k being kept constant at 50 mA. A batch will be passed if not more than one valve fails.
7. The end of life is defined as when 50 mA cathode current can no longer be obtained with $V_{g2} = 300V$. This shall be a factory life test in accordance with K1001 13.1 and for Type Approval purposes.
8. A maximum of 40 valves will be tested per month. For rates of production equal to or less than 40 per month, this corresponds to a 100% test. For higher rates there will be a corresponding reduction in the percentage tested.

ALL DIMENSIONS ARE IN MILLIMETRES

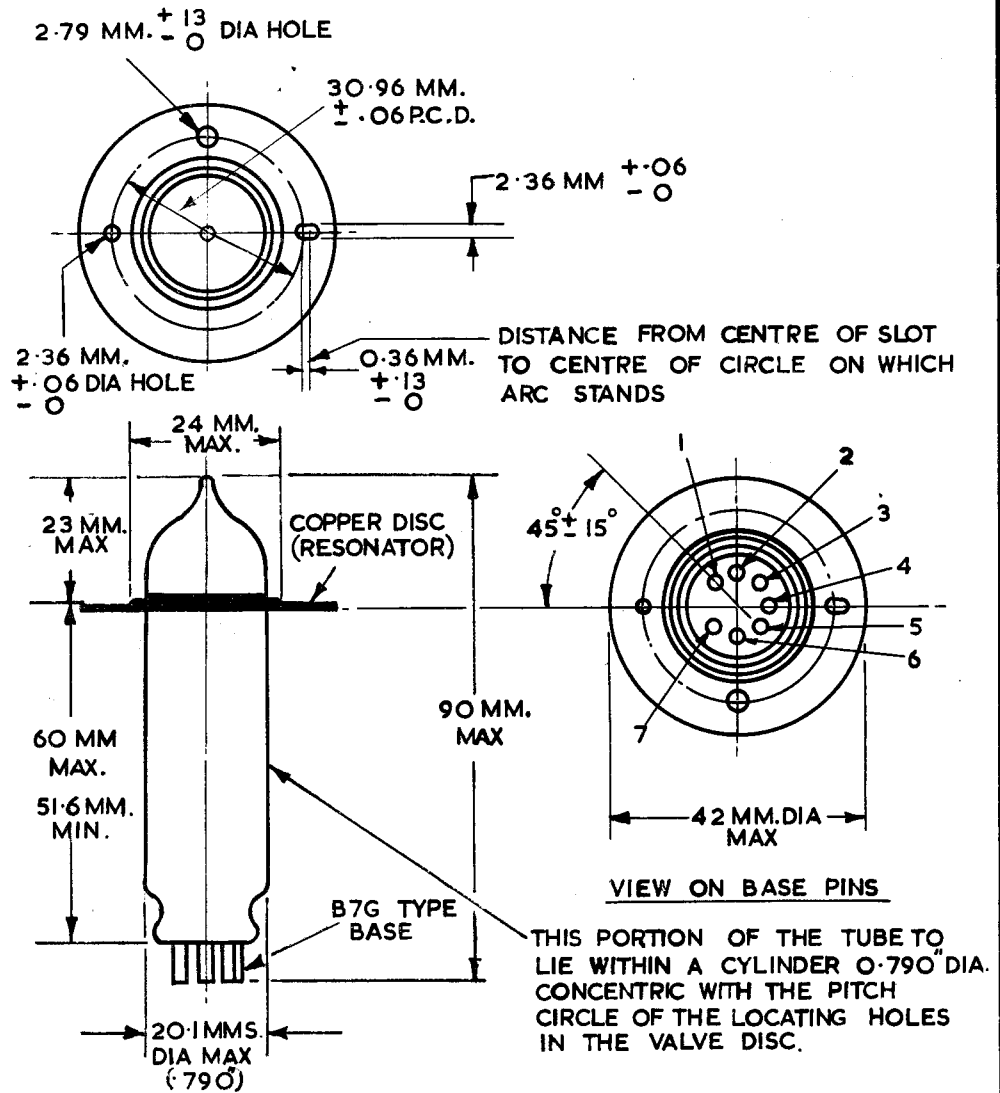

SCALE:- 1:1 3⁺