

MINISTRY OF SUPPLY - D.L.R.D.(A)/R.A.E.

Specification MOSA/OV1519 Issue 3 Dated 8.11.54 To be read in conjunction with B.S.448, B.S.1409 & K1001	<u>SECURITY</u>	
	<u>Specification</u> UNCLASSIFIED	<u>Valve</u> UNCLASSIFIED

-----&gt; Indicates a change

TYPE OF VALVE - Cathode Ray Tube TYPE OF DEFLECTION - Electrostatic, suitable for symmetrical deflection BULB - Internally coated with conductive coating. CATHODE - Indirectly heated SCREEN - To give a green trace PROTOTYPE - VCR.519	<u>MARKING</u> See K1001/4		
	<u>BASE</u> B.S.448/B12D		
	<u>CONNECTIONS</u>		
<u>RATING</u>	Note	Pin	Electrode
Heater Voltage (V) 4		1	g
Heater Current (A) 0.715		2	k
Max. First Anode Voltage (V) 500		3	h
Max. Second Anode Voltage (kV) 1		4	h
Max. Third Anode Voltage (kV) 4		5	a1
x-plate Sensitivity (mm/V) 720/Va3		6	a2
y-plate Sensitivity (mm/V) 720/Va3		7	NC
Max. Peak Beam Current (μA) 500		8	yN
Max. Out-off Voltage (V) 90		9	yS
		10	a3
		11	xW
		12	xE
<u>TYPICAL OPERATING CONDITIONS</u>			
First Anode Voltage (V) 450			
Second Anode Voltage (V) 460			
Third Anode Voltage (kV) 2.2			
<u>CAPACITANCES (pF)</u>			
C in	9.7		
xE to xW plate	4.6		
xE to all other electrodes	16		
xW to all other electrodes	16		
yN to yS plate	4.4		
yN to all other electrodes	15		
yS to all other electrodes	16		
(xE & xW) to (yS & yN) plates	3.3		
<u>DIMENSIONS</u> See Drawing on Page 4			
<u>NOTES</u>			
A. The screen calibration markings shall be made by sticking on an approved transparent material ( e.g. celluloid) printed with the markings shown on page 5.  The calibration shall be sufficiently accurate to pass the relevant tests given.			

To be performed in addition to those applicable in K.1001

Test Conditions					Test	Limits		No. Tested	Note
						Min.	Max.		
Deflection voltages shall be applied symmetrically in all cases									
	Vh	Va <sub>3</sub> (kV)	Va <sub>2</sub>	Va <sub>1</sub>	Vg				
a	4	-	-	-	-	Ih (A)	0.64	0.79	100%
b	4	2.2	Adjusted	450	Adjusted	(1) Line width (mm)	-	1.5	100%
						(2) Va <sub>2</sub> (V)	395	525	100%
Adjust Va <sub>2</sub> for optimum focus on a line of length 6". The line width is measured at the extremities at intervals of 45° by an approved microscope. Vg is adjusted till the microscope graduations are just clearly visible in a dimly lit room.									
c	4	2.2	As in test (b)	450	Adjusted to give out-off	(1) Vg (V)	-30	-90	100%
d	4	2.2	ditto	450	Adjusted	Voltage change (V)	-	9.0	100%
See K.1001/5A.3.2 Vg adjusted for Ib = 6.0 μA Insert resistor = 3 megohms, and re-set Ib to 6.0 μA									
e	4	2.2	ditto	450	Any convenient value	<u>PLATE SENSITIVITIES</u> (1) Less sensitive pair (mm/V) (2) Amount by which the more sensitive pair of plates may differ from 1.	655/ Va <sub>3</sub>	785/ Va <sub>3</sub>	100%  100%
f	4	2.2	ditto	450	ditto	Deviation of the spot from the mechanical centre of the screen (mm)	-	12	100%
g	4	2.2	ditto	450	ditto	Angle between x axis (E - W) and y axis (N - S)	89°	91°	100%
Deflection voltages applied to x and y plates successively, the pair of plates not in use being earthed.									
h	4	2.2	ditto	450	ditto	Deviation of bearings from calculated values	-	± 1°	100%
Deflection voltages calculated from known characteristics of the tube to give bearings at intervals of 22.5° with a 6" trace, are applied to the x and y plates.									

Test Conditions					Test	Limits		No. Tested	Note	
						Min.	Max.			
j	Vh 4	Va <sub>3</sub> (kV) 2.2	Va <sub>2</sub> As in test (b)	Va <sub>1</sub> 450	Vg Any con- venient value	Angle between N - S trace and diameter of the base through the spigot.  The North end of the N - S trace shall correspond to the spigot end of the diameter mentioned above	-	45° ± 10°	100%	
k	4	2.2	ditto	450	ditto	<u>CALIBRATION</u> Divergence of x and y scan lines from N.S.E.W. markings.	-	± 1/4°	100%	

**FIG 1.**

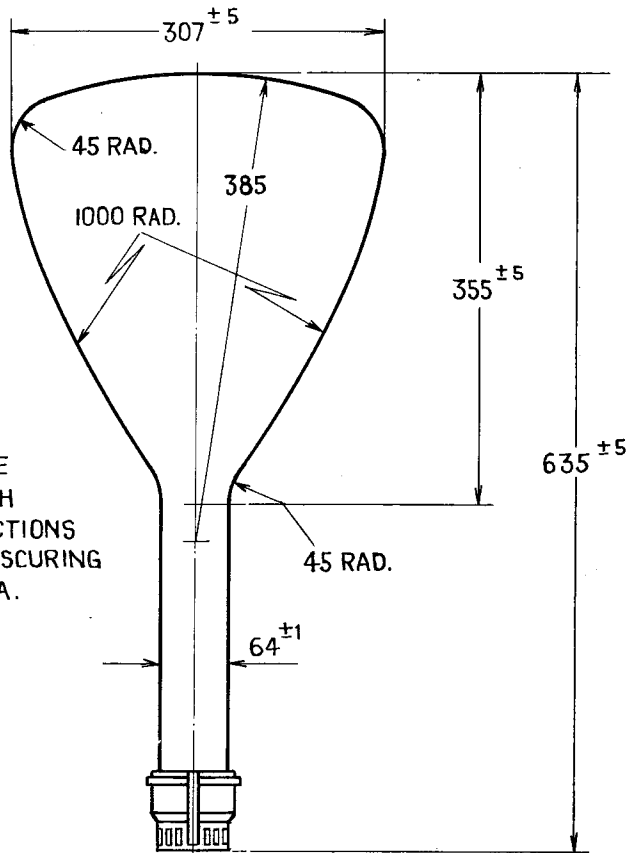

THE INTERNAL CONDUCTIVE COATING SHALL BE OF SUCH DIMENSIONS THAT IT FUNCTIONS EFFECTIVELY WITHOUT OBSCURING THE USEFUL SCREEN AREA.

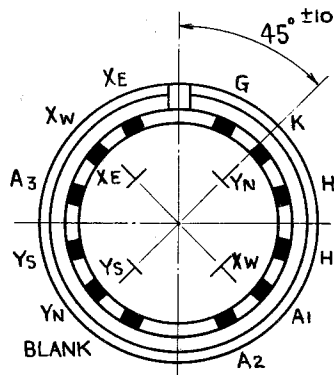

ALL DIMENSIONS IN MILLIMETRES.

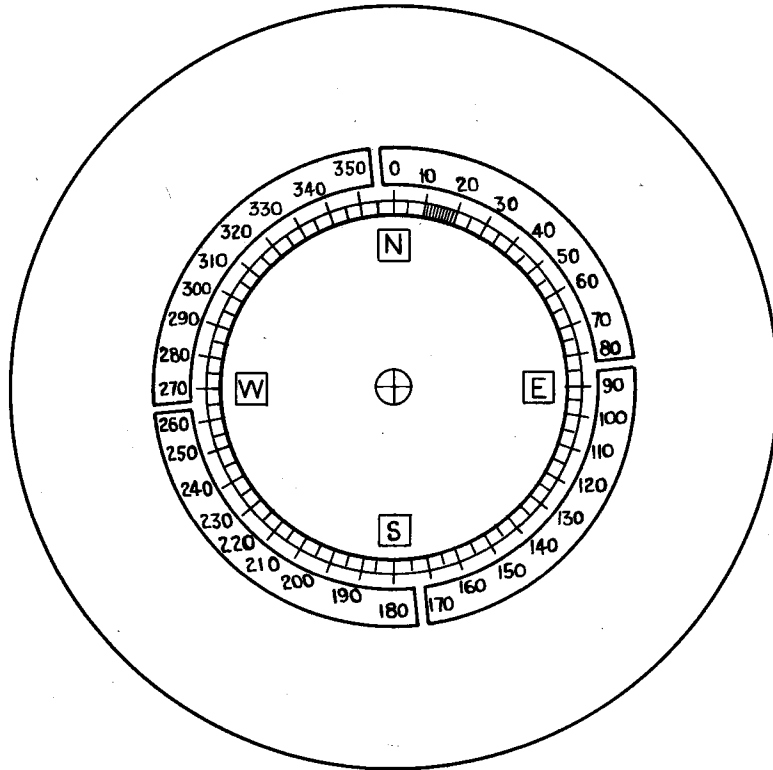
FIG. 2.NOTES

THE SCALE SHALL CONSIST OF FOUR QUADRANTS AND EACH QUADRANT SHALL BE SUB-DIVIDED INTO NINETY EQUAL DIVISIONS. THE SCALE SHALL BE CENTRED ON THE MECHANICAL CENTRE OF THE SCREEN.  
ALL MARKINGS ON THE SCALE SHALL BE BLACK.