

PHILIPS

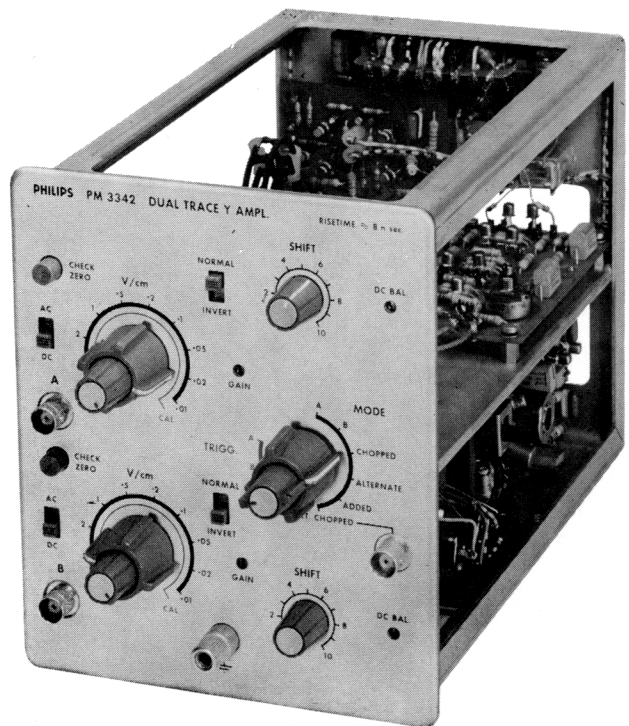

PM 3342 DUAL TRACE UNIT

IMPORTANT

In correspondence concerning this apparatus, please quote the type number and the serial number as given on the type plate at the rear of the apparatus.

Contents

GENERAL INFORMATION			
I. Introduction	7		
II. Technical data	7		
III. Description of the block diagram	9		
DIRECTIONS FOR USE			
IV. Installation	11		
V. Controls and their functions	13		
VI. Applications	15		
A. Amplitude measurements	15		
B. Differential measurements	15		
C. Phase measurements	16		
D. Single time-base	16		
SERVICE NOTES			
VII. Block diagram	17		
VIII. Vertical amplifier	23		
IX. Switching control-circuits	24		
X. Trigger amplifier	25		
		XI. Checking and adjusting	26
		A. General information	26
		B. DC balance	26
		C. Levels of channels A and B	27
		D. Sensitivity of channels A and B	27
		E. AC-DC switch; CHECK ZERO	27
		F. Square-wave response	27
		G. Frequency response curve	29
		H. Deflection and shift	29
		J. Input attenuators	29
		K. Blocking of channels A and B	30
		L. Rejection factor	30
		M. Triggering	30
		N. Chopping	31
		O. Alternate	31
		XII. Parts lists	32
		A. Mechanical	33
		B. Electrical	34

List of figures

Fig.		Page
1	Block diagram	9
2	Front view with indication of controls and connections	12
3	Block diagram (detailed)	19
4	Typical waveforms	22
5	Display	22
6	Right-hand view	26
7	TU-5 pulser	28
8	Left-hand view	28
9	Measuring probe, directly earthed	29
10	Input RC standardiser	30
11	Amplifier, channel A	38
12	Amplifier, channel B	39
13	Dual-trace unit	40
14	Output amplifier	40
15	Trigger amplifier	41
16	Drift compensator	41
17	Attenuator, channel A	44
18	Attenuator, channel B	48
19	Trigger-amplifier circuit	52
20	Dual-trace circuit	56
21	Y-amplifier circuit	61

GENERAL INFORMATION

Introduction



The PM 3342 is a dual-trace plug-in unit for the Y-channel of the PM 3330.

The unit contains two identical amplifiers with an electronic switch, by means of which two signals can be compared in amplitude and in phase.

Moreover, the sum and the difference of two input signals can be displayed.

Trigger of the time base occurs at choice on one of the two input signals or on the combined signal.

The amplifier data apply to channel A as well as to channel B.

Technical data



Note: Properties, expressed in numerical values with statement of tolerances are guaranteed by the factory. Numerical values without tolerances are intended for information purposes only and indicate the properties of an average apparatus.

Input circuit

input	adjustable AC or DC; push-button for checking the zero level
input impedance	1 M Ω //15pF
input	BNC
maximum permissible d.c. voltage in the a.c. position	400 V

Measuring probe

type	PM 9331 A/10
input	10 M Ω //8 pF
attenuation	1 : 10, tol.: 3%
permissible voltage	1,000V _{peak}

Amplifier

deflection coefficient	adjustable to 10 calibrated values: 10,20, 50 mV/cm etc., up to 10 V/cm; tolerance: 3% continuous attenuator 1 : 3 (non-calibrated)
bandwidth	D.C.: 0–50 Mc/s A.C.: 1.6 c/s – 50 Mc/s
rise-time	7 ns rise time of unit by itself: 5 ns
overshoot	$\leq 2\%$
rejection factor	$\geq 100 \times$ for frequencies ≤ 1 Mc/s in position D.C. provided that the amplifiers are adjusted to identical deflection-coefficients
maximum common mode input signal magnification	corresponding to 10 cm trace height 3 times useful screen height, symmetrical round the centre of the screen for frequencies up to 10 Mc/s. The top of a signal, which is magnified at maximum, can be displayed with the shift control.

polarity
phase difference
between both channels

reversible

not measurable on the screen

Switching possibilities

1. channel A
2. channel B
3. channels A and B chopped; frequency 500 kc/s or 20 kc/s (internal selection facility)
4. channels A and B alternately
5. channels A and B added
6. channels A and B externally chopped

externally chopped
voltage required

symmetrical square-wave voltage:

minimum, $1 V_{p-p}$,

maximum, $20 V_{p-p}$

repetition frequency

≤ 100 kc/s

rise time

1–100 ns

input capacitance

70 pF

Trigger mode

A, B or A + B (in position "ADDED" only)

trace height required in positions
DC, LF and HF

3 mm for frequencies up to 10 Mc/s

2 cm for frequencies up to 20 Mc/s

in position AUT.

1 cm for frequencies up to 1 Mc/s

in positions

TV LINE and TV FRAME

2 cm

Mechanical data

dimension

width 15 cm

height 17.5 cm

length 29 cm (knobs and plug included)

weight

3 kg

Accessories

1 Manual

Optional: 2 Measuring probes PM9331A/10

Description of the block diagram

III

Channels A and B each consist of an input circuit in which the "AC-DC" switch and the step attenuator are included, and an amplifier which contains the V/cm continuous attenuator, the SHIFT control and the polarity switch, see Fig. 1.

The switching of these channels occurs at the output of these amplifiers, after which the combined signal is applied to an output amplifier.

The switching circuit consists of a blocking oscillator

and a bi-stable multivibrator, which supplies the switching voltage. The trigger voltage for the basic oscilloscope is taken from one of the channels via a selector switch.

A trigger amplifier amplifies this voltage, so that the trigger signal and the Y-input signal have identical amplitudes.

In position "ADDED" of the "MODE" selector, the trigger signal is directly taken from the output amplifier.

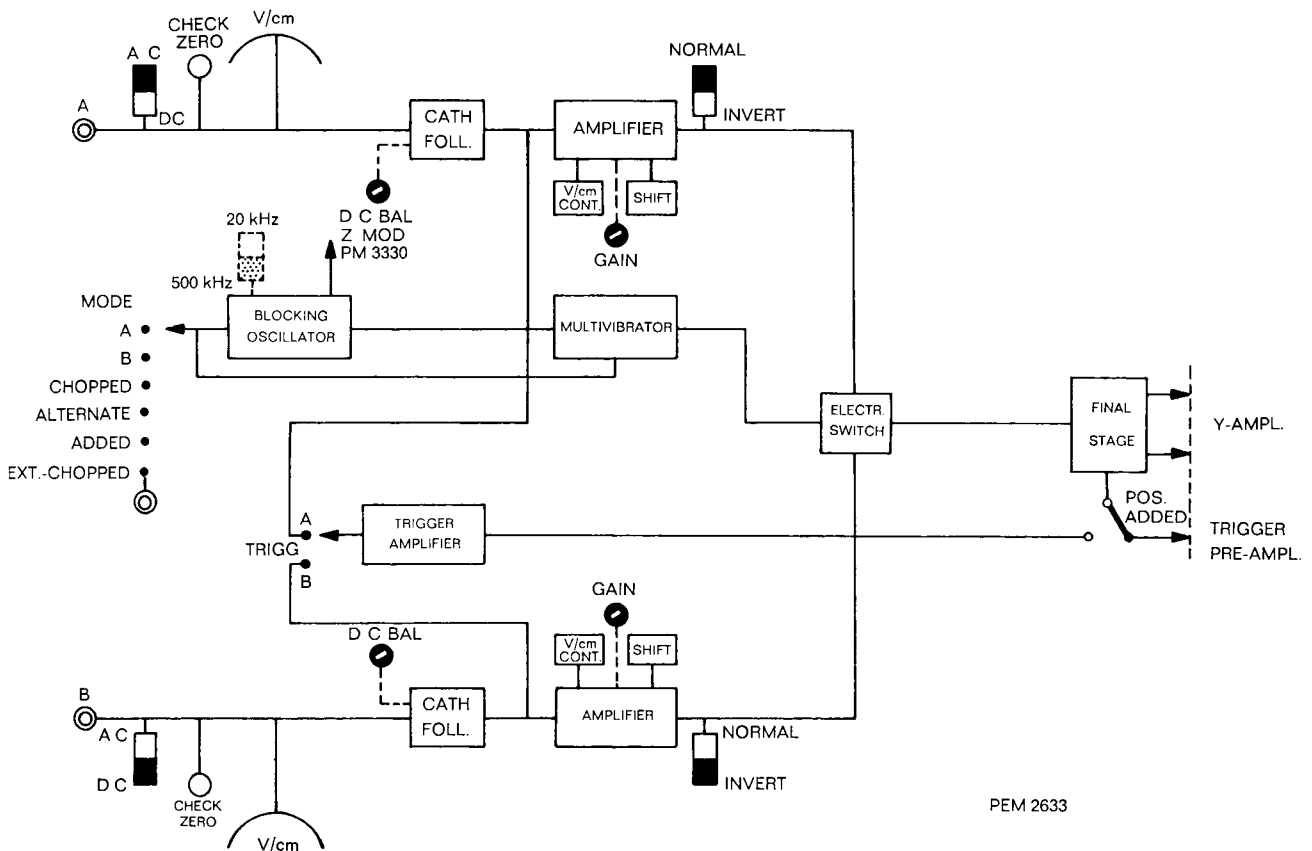

Fig. 1. Block diagram

DIRECTIONS FOR USE

Installation

IV

The PM 3342 should be plugged into the left plug-in compartment (Y-UNIT) of basic oscilloscope PM 3330. Switching-on is effected with the mains switch of the basic oscilloscope.

Approximately 10 minutes after switching-on, the

unit has reached its operating temperature and meets the technical data.

When using the PM 3342, the switch on the rear side of the basic oscilloscope should be set to position "MULTI-TRACE CHOPPER".

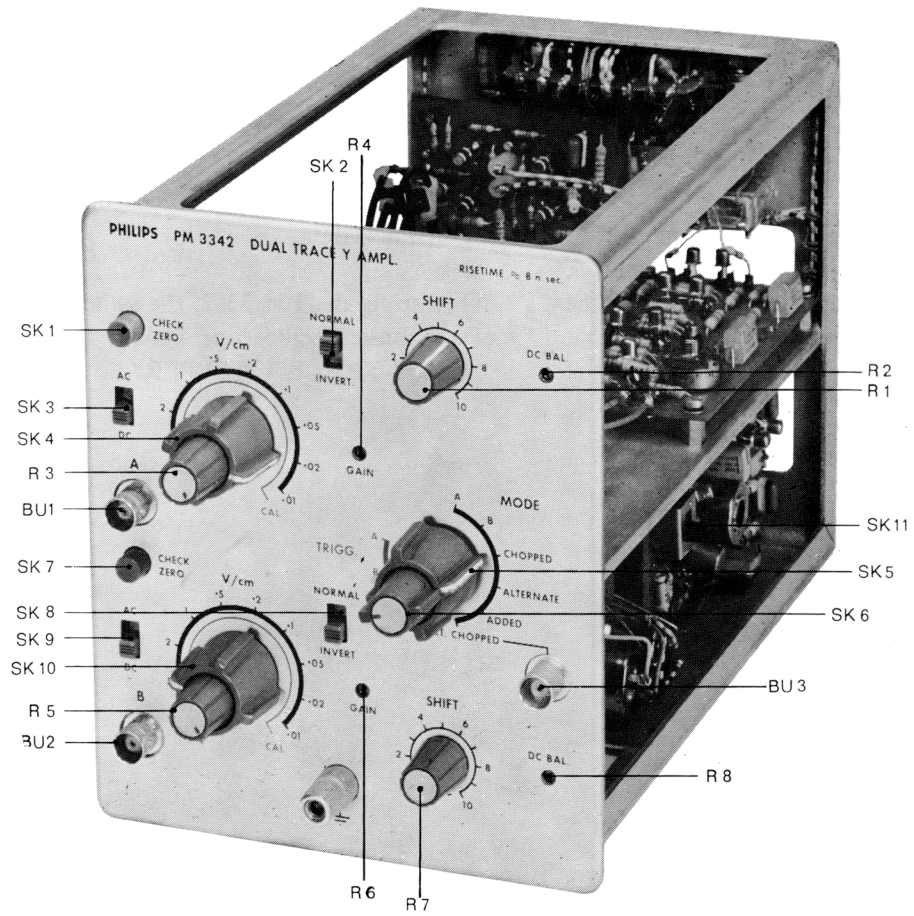
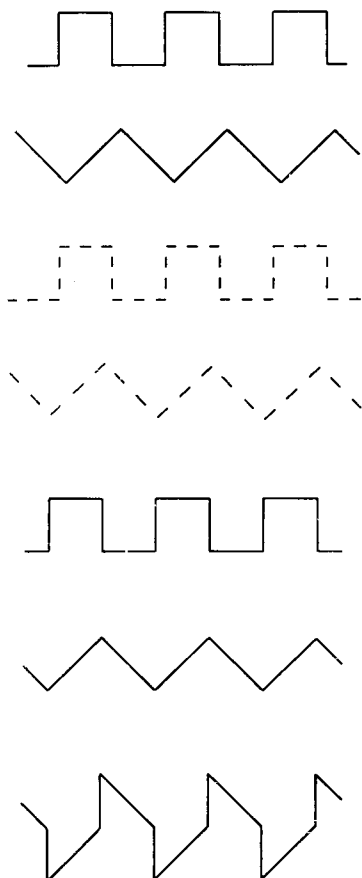

Fig. 2. Front view with indication of controls and connections

Controls and their functions (Fig. 2)

V

MODE selector SK5



The working mode of the unit can be selected with the six-position mode selector.

"A" channel A is switched in, channel B is out of action

"B" channel B is switched in, channel A is out of action

CHOPPED both channels are switched in. The voltages applied to sockets A and B are electronically switched. The frequency in which the channels are switched, can be adjusted to 20 kc/s or 500 kc/s with switch SK 11, located on a printed-wiring board at the right-hand side of the unit.

"ALTER-NATE" channels A and B are alternately displayed. Switching occurs during the flyback of the time-base voltage.

"ADDED" the voltages at the output of both amplifiers A and B are added. Dependent on the position of the polarity switches, the sum or the difference of the input signals is applied to the Y-amplifier of the basic oscilloscope.

"EXT. CHOPPED BU3" The channels are switched with a voltage, the frequency of which is equal to that of the voltage applied to socket "EXT. CHOPPED".

Trigger mode selector SK6

TRIGG A The trigger signal is equal to the voltage applied to socket A.

B The trigger signal is equal to the voltage applied to socket B.

When the MODE selector is in position "ADDED", the "TRIGG." switch is out of action. In that case the trigger signal is taken from the output amplifier.

Input circuit

AC-DC switch (SK3; SK9) Via this switch, the input socket is connected to the V/cm switch. In the DC-position, the entire input signal is fed to the V/cm switch; in the AC-position, the DC-component is blocked.

Push-button CHECK ZERO (SK1; SK7) By depressing this button the input circuit is interrupted and the amplifier input is earthed, so that the zero level can be checked.

Double knob V/cm (R3; R5) With this double knob the deflection coefficient of the amplifier can be adjusted.

The deflection co-efficients are calibrated when the continuous control is turned fully clockwise (position CAL.).

Polarity switch SK2 & SK8

"NORM.": a positive-going input signal causes an upward deflection on the screen.

"INVERT.": a positive-going input signal causes a downward deflection on the screen.

SHIFT knob R1 & R7

With this knob the trace can be shifted in Y-direction. The working-direction of this SHIFT knob is dependent on the position of the polarity switch.

GAIN control R4 & R6 (screw-driver adjustment)

The deflection coefficient of the amplifier can be checked by applying the calibration voltage of the basic oscilloscope to the input socket.

If the deflection coefficient does not correspond to the indicated value, it can be corrected by adjusting the GAIN control. In this case the continuous V/cm control should be turned fully clockwise (CAL.).

DC BAL. control R2 & R8 (screw-driver adjustment)

The DC-balance of the amplifier can be adjusted with this control.

For this, remove the input signal and adjust the time-base generator to its free-running position (TRIGG. MODE to position AUT., or STAB. fully clockwise). Adjust the DC BAL. in such way that the line on the screen does not move when rotating the continuous V/cm control.

Applications

VI

A. AMPLITUDE MEASUREMENTS

When measuring the amplitude of a signal, use is made of the calibrated deflection coefficients of the Y-deflection system (SK4; SK10).

Intermediate, non-calibrated deflection coefficients can be obtained by operating R3 and R5.

With the aid of the controls of the basic oscilloscope and the plug-in unit, make a triggered display visible. Check the zero level by means of button CHECK ZERO (SK1; SK7). (When the trigger-mode switch is in the AUT. position, the time-base line will remain visible during depression of push-button CHECK ZERO. When a different position is used, the time-base generator should be adjusted to its free-running position by means of the STAB. control).

The amplitude of the total signal is then equal to the product of deflection coefficient and the vertical deflection in cm.

Amplitude: $0.5 \text{ V/cm} \times 3.4 \text{ cm} = 1.7 \text{ V}$.

When only the AC-voltage should be measured, the DC-component can be removed from the signal with the aid of the AC-DC switch.

If measurements have been carried out via measuring probe PM 9331 A/10, the deflection coefficient of the V/cm switch should be multiplied by a factor 10.

The accuracy of the measurement can be increased by precisely adjusting the deflection coefficient with the GAIN control in the relevant position of the V/cm knob.

For this, the calibration voltage of the basic oscilloscope can be used.

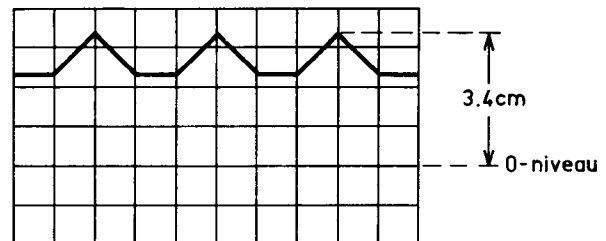
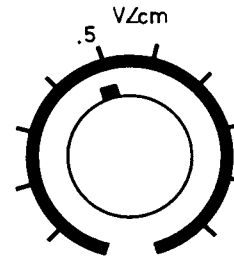

B. DIFFERENTIAL MEASUREMENTS

With these measurements, use is made of the common mode rejection of the amplifiers in position ADDED. When the polarity switches are set to opposite positions, two common mode signals on sockets A and B will undergo a very slight amplification with respect to two signals in anti-phase.

The signals on sockets A and B should not exceed a value corresponding to a trace height of 10 cm.

This common mode rejection can be adjusted to maximum by adjusting the amplifiers in such a way that their amplifications for the signal to be measured are exactly identical.

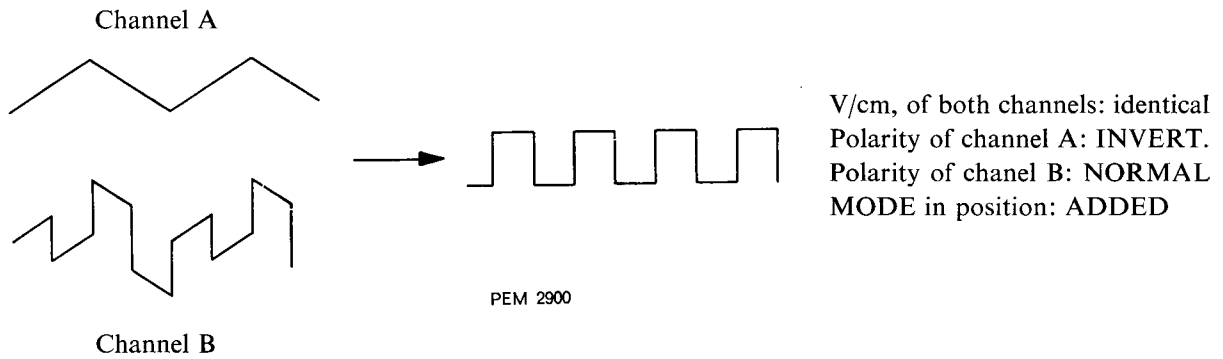

For this, simultaneously apply one of the signals to sockets A and B. Adjust the GAIN control in such a way that a minimum trace height is obtained on the screen.

After this, the common mode rejection will meet the value mentioned in the technical data.

C. PHASE MEASUREMENTS

If the phase difference between two signals is to be measured, the phase equality of both amplifiers of the PM 3342 is used.

It is recommended to set the MODE selector to position ALTERNATE. With low repetition frequencies of the time-base generator, this working mode results in a flickering display; in these cases the CHOPPED position should be used.

A high chopper frequency may lead to mutual influence of the two signals; therefore, it is recommended to set the frequency switch to the 20 kc/s position.

The signals are applied to socket A or B respectively. Make a triggered display visible with the controls of the basic oscilloscope and the PM 3342.

Both traces should be adjusted exactly symmetrical with respect to the centre horizontal graticule line. The phase difference can be read directly in degrees by adjusting knob TIME/cm (step- and continuous control of the basic oscilloscope) in such a way that one period of the signal to be measured corresponds to a whole number of centimetres on the screen.

D. SINGLE TIME-BASE

If the signal to be measured requires the use of the single-sweep display of the basic oscilloscope, the MODE switch of the PM 3342 should be set to position CHOPPED.

Selection of the switching frequency depends on the time coefficient of the X-deflection.

Generally, the highest chopper frequency will be used; for the lower time-base speeds however, also the lowest chopper frequency can be selected.

Set the controls in the TIME BASE A frame to the desired positions.

When the time-base generator is adjusted to its free-running position (STAB. control to REPET), it will start immediately after depressing push-button RESET.

When the STAB. control is in the trigger position, the time-base generator will start on the first trigger pulse, after depressing the RESET button.

During the time between depression of the RESET knob and starting of the time-base generator, the lamp in the RESET knob will light up.

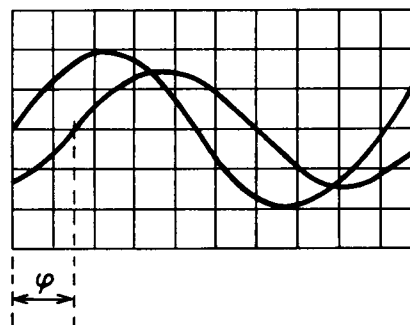

1 period = 9 cm

phase coefficient = $40^\circ/\text{cm}$

phase angle $\phi = 40^\circ/\text{cm} \times 1.6 \text{ cm} = 64^\circ$

SERVICE NOTES

Block diagram



Fig. 3 shows that each channel has independent control for: input coupling, attenuation, shift, balance and polarity. The output of each channel is controlled by a multivibrator-driven electronic switch, which feeds the common amplifier. Operation of this multivibrator in turn is controlled by the MODE switch SK5. The MODE switch can either hold the multivibrator in one of three states or select one of three operating modes for the blocking oscillator which drives the multivibrator. It will also be seen that internal trigger signals can be derived from one of three sources: channel A, channel B or the common amplifier output. The latter is automatically selected via SK5 and the relay, when the added mode is used. In this way, triggering on the desired signal is possible and triggering on the chopper is impossible.

Display MODE switch SK5.

In position A as well as in position B, the multivibrator is held in the stable state that allows the signal coming from the selected channel to pass through its electronic switch to the common amplifier.

In the ADDED position, the multivibrator is held in such a state that both electronic switches pass their signals to the common amplifier where they are added.

In the CHOPPED position the blocking oscillator is free-running either at 1 MHz or at 40 kHz, depending on the position of SK11 (inside the apparatus). Pulses from the blocking oscillator drive the multivibrator, which supplies anti-phase square-waves at 500 kHz or 20 kHz to the electronic switches. Thus: first the signal from one channel will pass to the common amplifier,

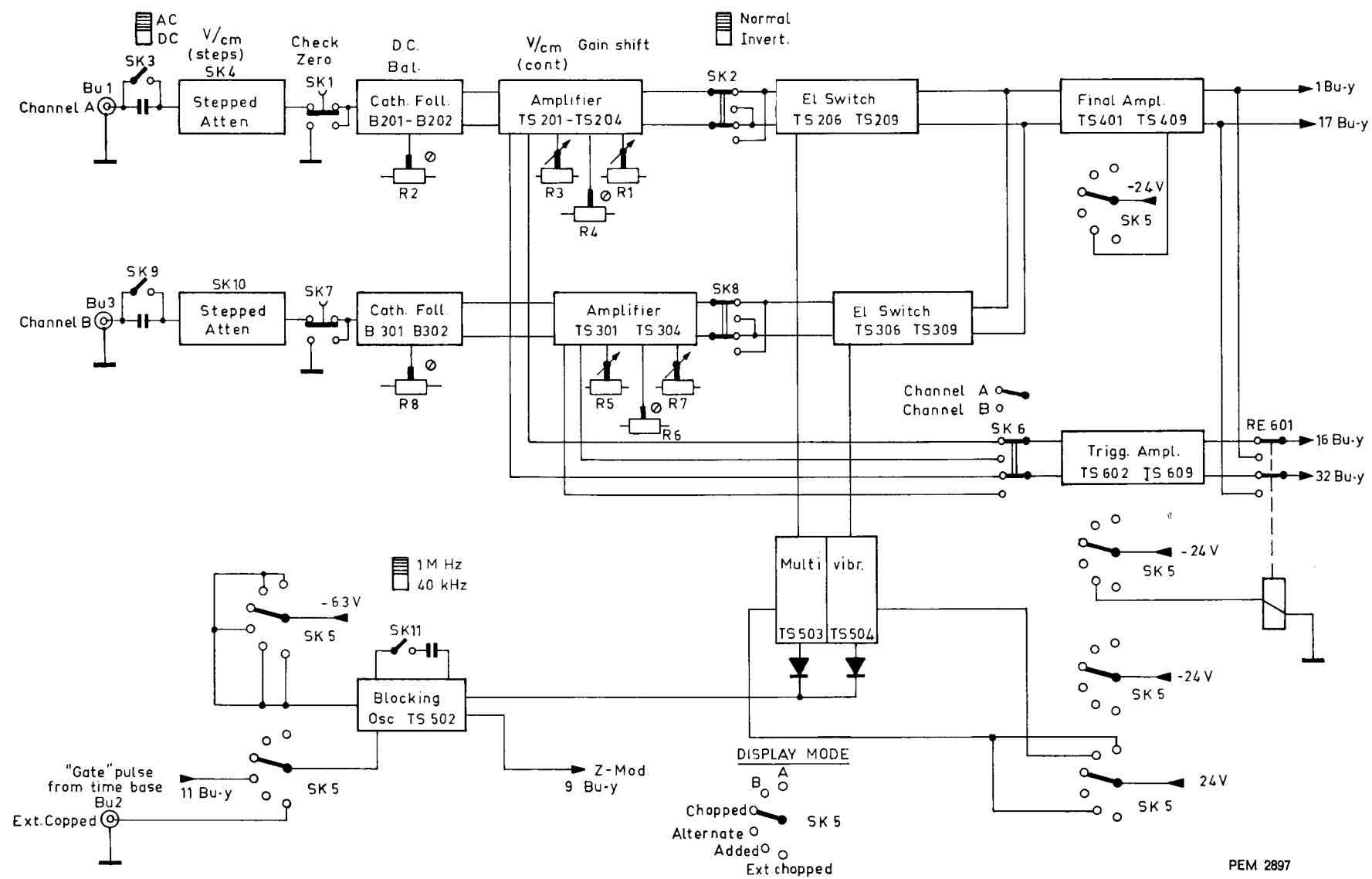

Fig. 3. Block diagram (detailed)

PEM 2897

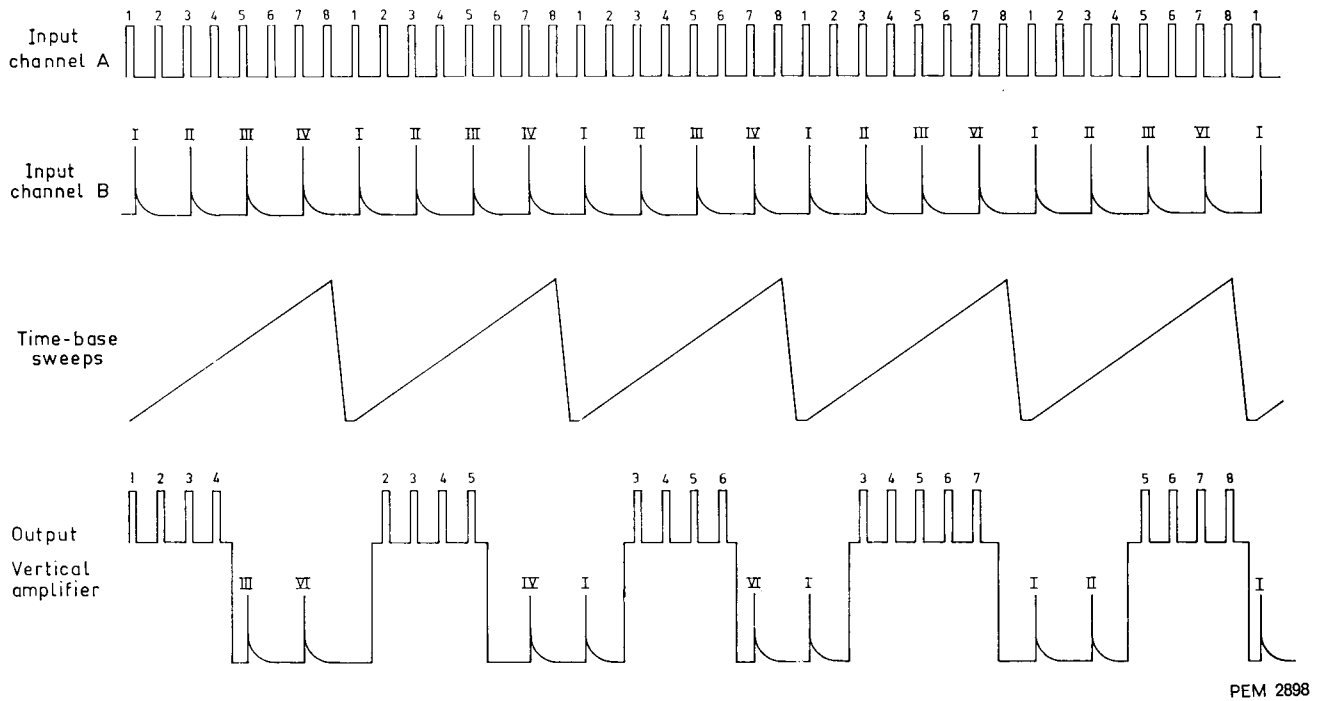

Fig. 4. Typical waveforms

then that from the other. In this way, the spot will follow a part of each signal in turn as shown in Fig. 4 and as it will not be the same part each sweep, the persistence of vision (and sometimes that of the CRT) will create the illusion of two complete waveforms on the screen, as shown in Fig. 5. To prevent hazing as the spot moves from one trace to the other, blanking pulses, derived from the blocking oscillator, are fed to the CRT via 9 BU-Y.

In the EXT. CHOPPED position, operation is the same as for CHOPPED, except that now the blocking oscillator will not be free-running but has to be triggered, via BU2, by an external signal.

In the ALTERNATE position, the blocking oscillator is triggered during the fly-back of the time-base. Thus the spot traces out first one signal and then the other.

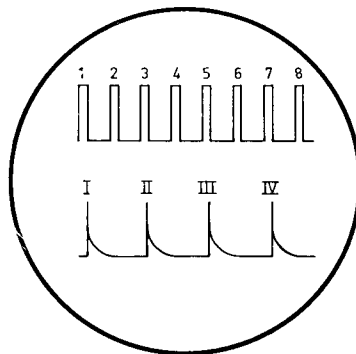

Fig. 5. Display

Vertical amplifier

VIII

1. Pre-amplifier channel A (Fig. 21)

The incoming signal is fed directly or via a capacitor depending on the position of switch SK3 (AC-DC), to a 10-step attenuator, which reduces the signal amplitude by a factor 1, 2, 5, 10 etc. up to 1000, as selected with switch SK4 (V/cm).

Cathode-follower B201 provides an impedance transformation to drive the following transistor amplifier. As the cathode-follower is subject to some DC-drift, a second cathode follower B202 is symmetrically connected to it to minimise drift. Furthermore, provision is made to balance the amplifier by varying the grid potential of B202 at R321 "COARSE DC-BALANCE" and R2 "DC-BAL".

When properly adjusted, no signal will be present across R3 (CONTINUOUS CONTROL) if the grid circuit of B201 is connected to earth with switch SK1 ("CHECK ZERO").

Clamping diodes GR202 and GR203 prevent the transistor amplifier (TS201-TS202) driving signal from becoming intolerably high in either the positive or the negative direction. Protecting diode GR201, which is normally forward biased, prevents the maximum (negative) grid-to-cathode voltage from being exceeded, because if such a signal is present, protecting diode GR201 will be reversely biased. The cathode voltage will then be determined by the -150 Volts supply and the voltage-drop across R206 due to the cathode current. To complete the temperature-compensation, the cathode circuit of B202 is likewise provided with diode GR206 of the same type. Diode GR204 prevents high voltages from being applied to TS202.

The second stage is formed by emitter-followers TS201 and TS202. They offer a low impedance signal source for the next stage and for the trigger-amplifier, which receives its signals via R232 and R237. From continuous control R3, the signal is routed to the third stage, TS203-TS204.

This stage can be regarded as an asymmetrically driven long tailed-pair amplifier.

The output of this stage consists of two equal, but opposite, signals. GAIN control R4 influences the negative feedback and consequently the amplification factor. R235 and C211 provide a correction to obtain optimum step-response.

Shift controls Y-SHIFT (R1-R1') and the polarity switch SK2 are inserted between the third and fourth stage. The connections from the third stage to SK2 and from SK2 to the fourth stage are effected by means of a 300 Ohm ribbon line, which is terminated by R249 and the series-connection of R254-R256. The power is

supplied at the junction of R254-R256. In this way, the total dynamic resistance at the collectors of TS203 and TS204 amounts to 75 Ohms.

The fourth stage consists of two cascode amplifiers (TS206-TS208 and TS207-TS209) which are push-pull connected. Transistors TS206 and TS207 act as current sources to the low-ohmic inputs of TS208 and TS209 respectively. Thus hardly any signal voltage will be present at the emitters of TS208 and TS209, so it is possible to carry out the electronic switching at this point.

If the voltage at R508 becomes more positive than the emitter voltage, switching diodes GR209 and GR211 are blocked, thus allowing normal operation of the cascode-amplifiers. If the voltage at R508 is decreased below the potential at the bases of TS208 and TS209, the transistors are fully blocked and diodes GR208 and GR212 likewise. So no signals will pass and channel A is cut off.

In the emitter circuit of TS206 and TS207, R263 and C217 provide low frequency compensation; C218 improves the step-function response.

2. Pre-amplifier channel B (Fig. 21)

This pre-amplifier is identical to that of channel A. The switching voltage of channel B however, is counter-phased. Thus the diodes GR309-GR311 are conductive when GR209-GR211 are blocked and vice versa. As a result, the signal of channel A is displayed when channel B is blocked and vice versa.

3. Output amplifier (Fig. 21)

The driving signals of the output amplifier are developed across R402 and R406. Emitter-followers TS401-TS402 offer these signals with a low source impedance to cascode-amplifiers TS403-TS406 and TS404-TS407. The amplified signals are finally routed to the output stage consisting of emitter followers TS408-TS409 which make them available to the vertical amplifier of the basic oscilloscope via terminals 1 and 17 of BU-Y. When the MODE-switch SK5 is in position ADDED, diodes GR209-GR211-GR309-GR311 are blocked simultaneously so that both channels are switched in and a combined signal is applied to the output amplifier. To maintain the same voltage-level at R404, R401 is connected in parallel.

The two cascode-amplifiers are connected in push-pull arrangement with a high common resistance at the emitter side of TS403-TS404 thus forming one differential amplifier. C422, C401 and R413 improve the step-function response.

Switching control circuits

IX

1. Blocking oscillator (Fig. 20)

If SK5 is in the CHOPPED position, switch SK5 1A is open, so that the potential at the base of TS502 is determined by voltage-divider R 504-506. It is adjusted so that the blocking oscillator become astable, operating at a repetition rate of 40 kHz or 1 MHz depending on the position of SK11).

In all other positions of SK5, switch SK5 1A is closed, thus setting the base to approximately emitter-potential. TS502 is almost cut-off but it will operate when a negative pulse arrives at the base from terminal 4 of S2 (transformer T501).

If SK5 is in the ALTERNATE position, C500 and R511 differentiate a negative-going pulse, which arrives at terminal 11 BU-Y and which has the same duration as the GATE pulse of the basic oscilloscope. The positive-going spike resulting from the trailing edge, is passed by diode GR507 to emitter-follower TS501, which injects it into winding S5 of transformer T501. The inverted pulse is applied to the base of TS502, which triggers the blocking oscillator to deliver one pulse, after which the oscillator returns to its quiescent state.

If SK5 is in the EXT. CHOPPED position, the signal entering at BU2 is differentiated by C500 and R511 and triggers the blocking oscillator as mentioned under ALTERNATE.

Every time the blocking oscillator operates, a pulse

appears at winding S1 of transformer T501. It is routed to terminal 9BU-Y to momentarily blank the display on the screen. To ensure that the blanking pulses reach the CRT at the moment that the switching pulse (delayed by the vertical amplifier) reaches the Y-deflection plates, a 120 nanosecond delay-line is fitted in the main frame. Resistor R503 (470 Ω) terminates this delay line to avoid reflections.

2. Multivibrator (Fig. 20)

The bi-stable multivibrator TS503-TS504 is locked in position: TS503 cut-off. TS504 conductive, when MODE selector SK5 is in position A. As a result, the electronic switch of channel A is closed and that of channel B is open.

When SK5 is in position B, TS504 is blocked and the signal of channel B is displayed.

When SK5 is in the ADDED position, both transistors are blocked and both electronic switches are therefore closed. When SK5 is in the CHOPPED, ALTERNATE or EXT. CHOPPED positions, the bi-stable multivibrator switches at half the rate of the blocking oscillator.

It may be observed that switching diodes GR501 and GR502 are conductive when their appertaining transistors are conductive. They then offer a low ohmic path to an incoming negative switching pulse. The transistor will be blocked and also the diode which will then turn into a high-ohmic impedance.

Trigger amplifier



The trigger amplifier (Fig. 19) consists of four push-pull stages which are directly coupled to each other. The first three stages are long-tailed pair amplifiers; the fourth stage is connected as an emitter-follower output – stage. The balance of the amplifier is adjusted at the first stage by R605; the quiescent DC-level of the output is adjusted by changing the value of R623. The output of the trigger amplifier is connected to the

trigger amplifier of the main frame via contacts of relay RE601.

When MODE selector SK5 is in the ADDED position, the relay is energised and the output of the trigger amplifier is disconnected. The main frame trigger amplifier is then connected to the output of the vertical amplifier.

Checking and adjusting

XI

A. GENERAL INFORMATION

The tolerances mentioned are factory tolerances; they apply when the apparatus is readjusted completely. They may differ from the data given in II.

A summary of the adjusting elements, their nomenclature and location has been given in V.

With the aid of these data, it is possible to carry out all the adjustments of the dual trace unit PM 3342 and to check the proper working of the plug-in unit.

For this, the unit should be inserted into the Y-plug-in compartment of a correctly adjusted basic oscilloscope PM 3330.

Some of the adjusting elements are on the right-hand side of the unit and are not directly accessible. When these elements must be adjusted, the unit should be connected to the basic oscilloscope via the rigid extension plug (code number 4822 263 70009).

For a complete adjustment of the instrument the sequence as described in this chapter is to be preferred.

B. D.C. BALANCE

This adjustment should be carried out when the unit has obtained its operating temperature, i.e. approximately 15 minutes after switching-on. Set the knobs of the basic oscilloscope to the following positions:
 "TRIGG. MODE": "AUT."
 "TRIGG. SOURCE": "INT."
 "TIME/cm": "2 msec./cm"
 "X-DEFLECTION": "TIME BASE A"

1. Channel A

R213 (Fig. 6)

- Set "MODE" (SK5) to "A" and turn "D.C. BAL." (R2) to its mid-position.

During this adjustment, keep the time-base line on the screen with "SHIFT" (R1).

- Adjust the coarse control "D.C. BAL." (R213) so, that the time-base line hardly moves when "V/cm" (R3) is turned fully clockwise or anti-clockwise.
- With the fine control "D.C. BAL." (R2), adjust for a stationary display.

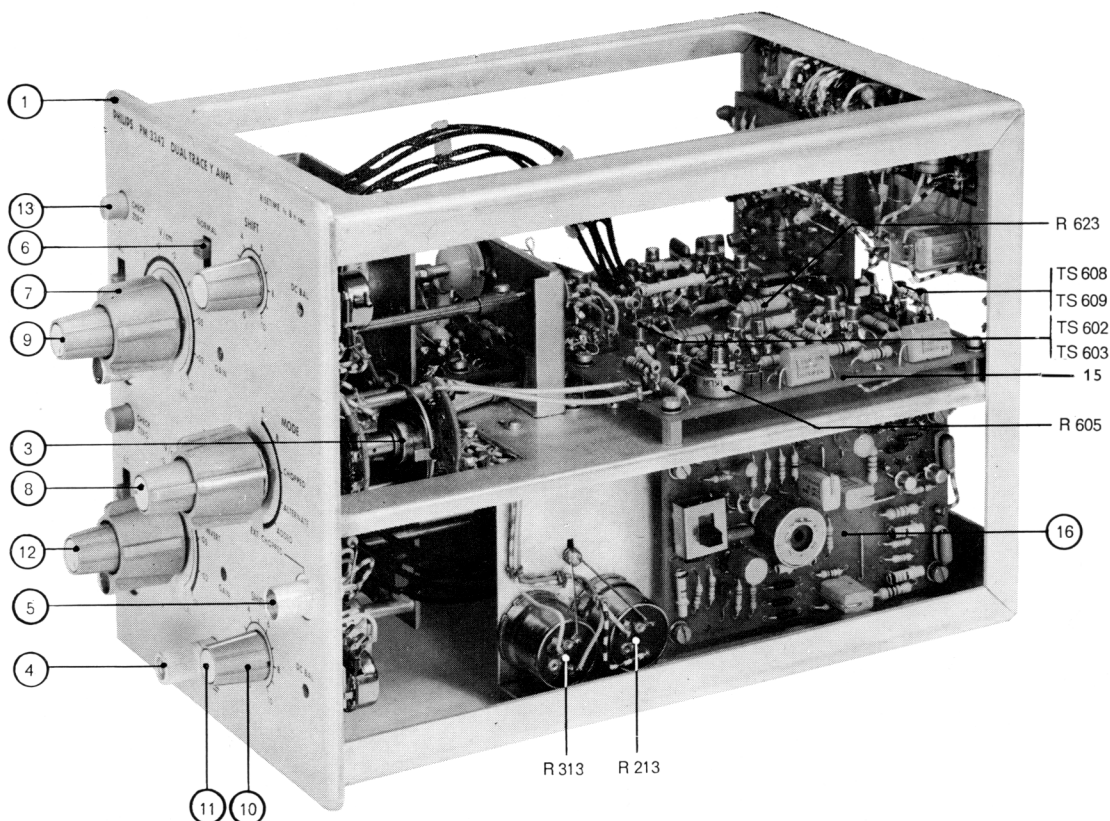

Fig. 6. Right-hand view

2. Channel B

R313 (Fig. 6)

- Set "MODE" (SK5) to "B" and turn "D.C. BAL." (R8) to its mid-position.
During this adjustment, keep the time-base line on the screen with "SHIFT" (R7).
- Adjust the coarse control "D.C. BAL." (R313) so, that the time-base line hardly moves when "V/cm" (R5) is turned fully clockwise or anti-clockwise.
- With the fine control "D.C. BAL." (R8), adjust for a stationary display.

3. Trigger amplifier

R605, R623 (Fig. 6)

The d.c. balance and the output level of the trigger amplifier are adjustable with "BAL." (R605) and choice resistor R623.

These adjusting elements are accessible if the unit to be measured is connected to the basic oscilloscope via the extension plug.

- Short-circuit the input of the trigger amplifier by interconnecting the bases of transistors TS602 and TS 603 (See Fig. 6).
- Measure the voltage on the output of the amplifier between the emitters of transistors TS608 and TS609. (See Fig. 6).
- Adjust this voltage to minimum with "BAL." (605R).
- Check the voltage level of both points with respect to earth; this should amount to + 18 V, tolerance + or - 2 V.
If necessary select a different value for R623.
- Remove the interconnection.

C. LEVELS OF CHANNELS A AND B

- Set "MODE" (SK5) to "A" and adjust "SHIFT" (R1) so that the trace does not jump when "POLARITY" (SK2) is switched-over.
- Set "MODE" (SK5) to "B" and adjust "SHIFT" (R7) so that the trace does not jump when "POLARITY" (SK8) is switched-over.
- In both cases, the vertical position of the time-base line should not deviate more than 1 cm from the centre of the screen.

D. SENSITIVITY OF CHANNEL A AND CHANNEL B

- Set the below mentioned knobs to the following positions:
"V/cm" (SK4) and "V/cm" (SK10) to ".01"
"MODE" (SK5) and "TRIGG." (SK6) to "A"
"V/cm" (R3) and "V/cm" (R5) to "CAL".
- Adjust the calibration voltage of the basic oscilloscope to 40 mV and apply this voltage to channel A.

- With "GAIN" (R4), adjust the sensitivity so, that the trace height of the reproduced square-wave voltage is 40 mm.
- Set "MODE" (SK5) to "ADDED" and "POLARITY" (SK2 and SK8) to "NORMAL" and "INVERT" respectively.
- Also apply the 40-m V calibration voltage to channel B by interconnecting the inputs of both channels.
- With "GAIN" (R6), adjust the sensitivity of channel B so, that it is equal to that of channel A; in this case no vertical deflection is visible.
- Set "MODE" (SK5) to position "A".
- Check that the sensitivity of channel A can be continuously controlled with "V/cm" (R3).
- With R3 fully anti-clockwise, the sensitivity should be so reduced that the trace height does not exceed 16 mm.
- Set "MODE" (SK5) to position "B".
- Set "TRIGG." (SK6) to position "B".
- Check that the sensitivity of channel B can be continuously controlled with "V/cm" (R5).
- With R5 fully anti-clockwise, the sensitivity should be so reduced that the trace height does not exceed 16 mm.

E. A.C./D.C. SWITCH; CHECK ZERO

- Set the below mentioned knobs to the following positions:
"POLARITY" (SK2-SK8) to "NORMAL"
"A.C./D.C." (SK3-SK9) to "D.C."
"MODE" (SK5) to "A" and "B" respectively
"TRIGG." (SK6) to "A" and "B" respectively
"V/cm" (SK4 and SK10) to ".01 V"
- Adjust the calibration voltage of the basic oscilloscope to 40 mV and apply this voltage to channel A (channel B).
- Adjust "SHIFT" (R1) (R7) so, that the lower side of the trace coincides with the centre line of the screen.
- Set SK3 (SK9) to "A.C."
In both channels the DC-components should be blocked, as a result of which the trace is written approximately symmetrically around the centre line of the screen.
- If "CHECK ZERO" is depressed, the trace should no longer be visible.

F. SQUARE-WAVE RESPONSE

To avoid extra capacitive load on the output of the amplifier, this adjustment should be carried out without using the extension plug. To check the rise time and the overshoot, a square-wave voltage with a value of 40 mV_{p-p} and a rise time of 1.5 nsec. is required. This voltage can be obtained with the aid of a pulser

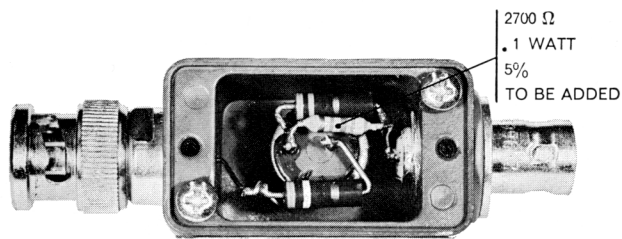

Fig. 7. TU-5 pulser

which is controlled with the aid of the calibration voltage of the basic oscilloscope; the output voltage of the pulser can be adjusted to the required value by means of an attenuator. If a Tektronix TU-5 Pulser (cat. nr. 015-0038-00) is used a 2700 Ω resistor (.1 Watt, 5%) must be added as shown at Fig. 7.

– Set the knobs of the basic oscilloscope to the following positions:

"TIME/cm": ".05 μ sec./cm"

"MAGNIFIER": " $\times 5$ ".

1. Channel A

– Set the knobs mentioned below to the following positions:

"V/cm" (SK4) to ".01".

"V/cm" (R3) to "CAL."

"MODE" (SK5) and "TRIGG." (SK6) to "A".

– Apply a 40 mV square-wave with a rise time of ≤ 25 nsec. to BU1.

– Adjust the frequency to 200 Hz and the timebase to 2 msec/cm.

– Select C217 and R263 so that optimum squarewave display is obtained.

– Increase the frequency to 10 kHz and the timebase to 50 μ sec./cm.

– Select C215 and R255 so that optimum squarewave display is obtained.

– Increase the frequency to 100 kHz and the timebase to 2 μ sec./cm.

– Select C211 and R235 so that optimum squarewave display is obtained.

– Increase the frequency to 1 MHz and the timebase to .5 μ sec./cm.

– Select C422 and R413 so that optimum squarewave display is obtained.

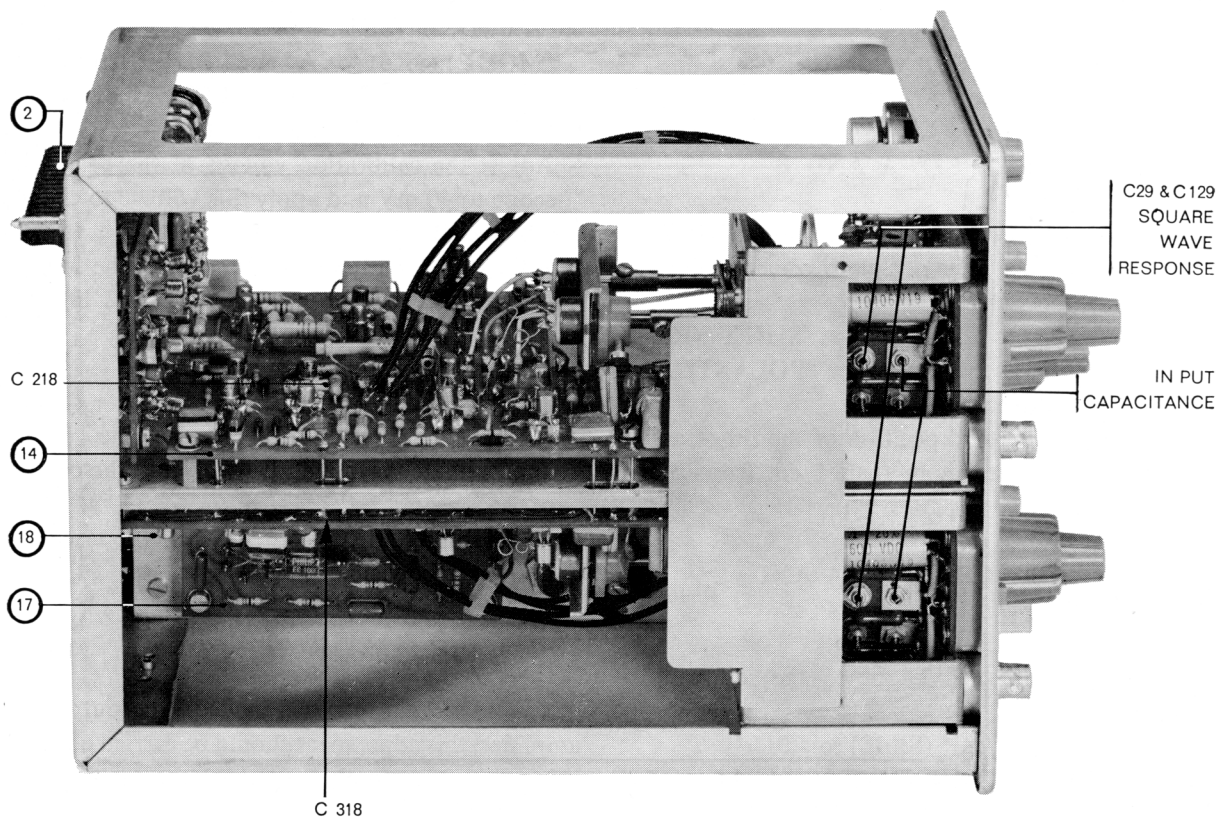

Fig. 8. Left-hand view

- Connect the pulser to BU1 via a 1 : 5 attenuator (e.g. Tektronix cat. no. 011 – 0060 – 00) and a 50-Ohm pad (e.g. XE 101.96 order no. 4822 263 60013) and apply the calibration voltage of the basic oscilloscope (80 V) to the pulser. Adjust the pulser by turning its knob clockwise so that its output voltage instantly obtains the correct value.
- Select C218 so that the rise time is minimum (TIME/cm: .05 μ sec/cm and "MAGN": X5, i.e. 10 nsec./cm in total) and that the overshoot does not exceed 1%.
To check the overshoot, the time coefficient of the basic oscilloscope should be adjusted to 1 μ sec./cm.
- Apply a square-wave voltage with a frequency of .3 Hz respectively 20 Hz and a rise time of \leq 25 nsec.
- Check that in both cases the display shows no tilt.

2. Channel B

- Set the knobs mentioned below to the following positions:
"V/cm" (SK10) to ".01".
"V/cm" (R5) to "CAL.".
"MODE" (SK5) and "TRIGG." (SK6) to –B".
- Apply a 40-mV square-wave with a rise time of \leq 25 nsec. to BU2.
- Adjust the frequency to 200 Hz and the time base to 2 msec./cm
- Select C317 and R363 so that optimum squarewave display is obtained.
- Increase the frequency to 10 kHz and the time base to 50 μ sec./cm.
- Select C315 and R355 so that optimum squarewave display is obtained.
- Increase the frequency to 100 kHz and the time base to 2 μ sec./cm.
- Select C311 and R335 so that optimum squarewave display is obtained.
- Connect the pulser to BU2 via a 1 : 5 attenuator and a 50-Ohm pad (see point F1) and apply the 80-V calibration voltage.
- Select C318 so that the rise time is minimum ("Time/cm": .05 μ sec./cm and "MAGN." :X5, i.e. totally 10 nsec./cm) and that the overshoot does not exceed 1%.
To check the overshoot, the time coefficient of the basic oscilloscope should be adjusted to 1 μ sec./cm.
- Apply a square-wave voltage with a frequency of .3 Hz resp. 20 Hz and a rise time of \leq 25 nsec.
- Check that, in both cases, the display shows no tilt.

G. FREQUENCY RESPONSE CURVE

After adjusting the square-wave response of both channels (see F1-2), the –3 dB point of the amplifier should lie at a frequency above 50 MHz. The frequency response curve can be measured with e.g. the PHILIPS

A.M./F.M.-generator GM 2621 and the PHILIPS H.F.-millivoltmeter GM 6025. Check at the input of both channels that the voltages required for the measurement of the frequency response curve are equal. For this, connect the measuring pin of the probe to the centre contact of the A.C./D.C. switch; the casing of the measuring probe should be directly earthed, so without the use of the earthing cord (as in Fig. 9).

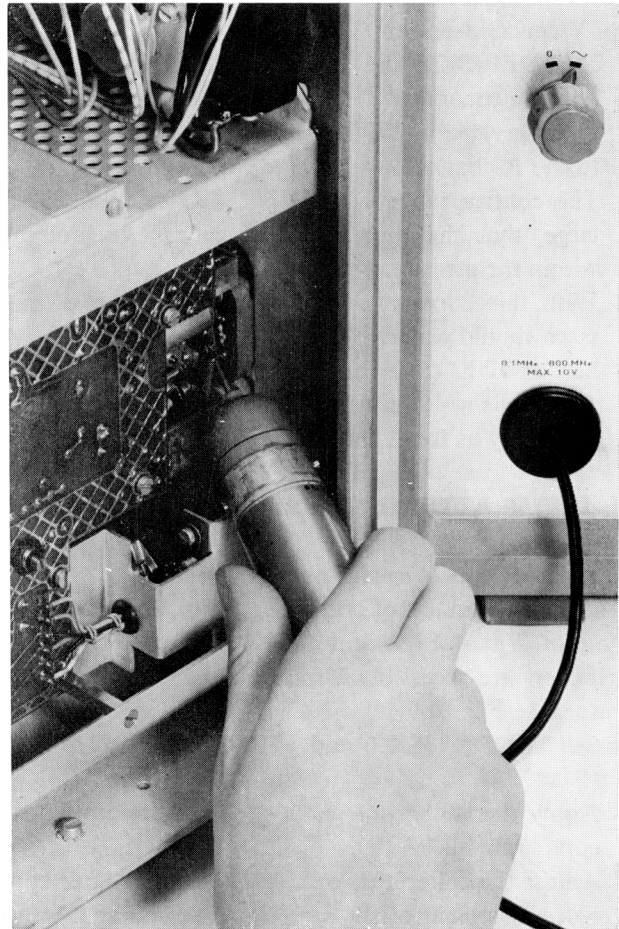

Fig. 9. Measuring probe, directly earthed

1. Channel A

- Set the knobs to the positions mentioned under F1.
- Connect output socket H.F. II of the GM 2621 to the input of channel A via a terminated 50- Ω cable. A 50- Ω terminating plug XE 101.96 (code nr. 4822 263 60013) can be used.
- Adjust the frequency to 4.5 MHz and adjust the generator voltage so, that a deflection of 6 cm is obtained.
- Increase the frequency to 50 MHz.
With the same value of the input voltage, the deflection should exceed 4.2 cm.

2. Channel B

- Set the knobs to the positions mentioned under point F2.
- Connect the generator to the input of channel B and check the frequency response curve in the same way as indicated for channel A.

H. DEFLECTION AND SHIFT

Before carrying out this measurement, check that the DC-balance and the sensitivity of both channels have been correctly adjusted (see points B1-2 and D).

- Set the below mentioned knobs to the following positions:
 - "A.C. D.C. (SK3-SK9) to "A.C."
 - "V/cm" (SK4-SK10) to ".01 V"
 - "V/cm" (R3-R5) to "CAL."
 - "MODE" (SK5) and "TRIGG." (SK6) to "A"
- Apply a triangular or sine-wave voltage with a peak-to-peak value of 180 mV and a frequency of 2 kHz to the A-channel.
- The control range of "SHIFT" (R1) should be so large, that the tops of the trace can be brought within the measuring graticule.
- With this triple overdriving, no distortion of the trace should occur.
- Set "MODE" (SK5) and "TRIGG." (SK6) to "B".
- Apply the voltage to channel B and check in the same way as for A the shift and the deflection.

J. INPUT ATTENUATORS

1. Attenuation and square-wave response

For the adjustment of both attenuators, in every position of V/cm (SK4 and SK10), the corresponding trimmers are accessible from the outside of the attenuator (see Fig. 8).

- Set "MODE" (SK5) and "TRIGG." (SK6) to "A" (B).
- Apply the calibration voltage of the basic oscilloscope to channel A (B).
- Adjust the calibration voltage to 40 mV. After correct adjustment of the sensitivity (see point D), the trace height should amount to 40 mm.
- Check the trace height in all other positions of "V/cm" (SK4, SK10 resp.) according to the following table; this trace height should amount to 40 mm + or - 2½%.
- At the same time, adjust the trimmers mentioned in the table for optimum square-wave response.

Calibration voltage	V/cm (SK4-SK10)	Channel A	Channel B
40 mV	.01		
80 mV	.02	C32	C132
.2 V	.05	C34	C134
.4 V	.1	C38	C138
.8 V	.2	C42	C142
2 V	.5	C46	C146
4 V	1	C49	C149
8 V	2	C53	C153
20 V	5	C57	C157
40 V	10	C61	C161

2. Input capacitance

With the aid of an input RC standardiser, (e.g. Tektronix cat. nr. 011-0073-00 BNC) the input capacitance can be adjusted to 15 pF in all positions of "V/cm" (SK4-SK10). See also Fig. 10.

- Set "MODE" (SK5) and "TRIGG." (SK6) to "A" (B).
- Apply the calibration voltage of the basic oscilloscope to channel A (B) via the input capacitance standardiser.
- Adjust the input capacitance of both channels by means of the trimmers mentioned in the table below so, that the square-wave response is optimum.

Calibration voltage	V/cm (SK4-SK10)	Channel A	Channel B
80 mV	.01	C29 (if necessary, C28)	C129 (if necessary, C128)
.2 V	.02	C33	C133
.4 V	.05	C36	C136
.8 V	.1	C39	C139
2 V	.2	C43	C143
4 V	.5	C47	C147
8 V	1	C51	C151
20 V	2	C54	C154
40 V	5	C58	C158
80 V	10	C62	C162

K. BLOCKING OF CHANNELS A AND B

- Set "MODE" (SK5) to "A"
- In this position, channel B should be blocked. Check this by turning "SHIFT" (R7); this should have no

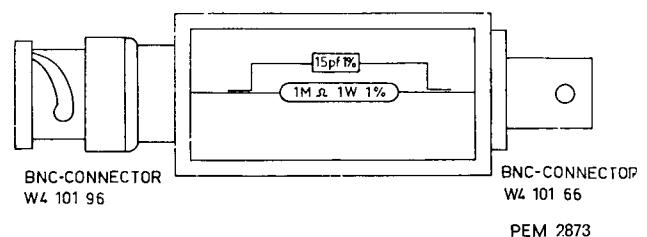

Fig. 10. Input RC standardiser

- influence on the position of the time-base line.
- Set "MODE" (SK5) to "B".
- Check in the same way the blocking of channel A by turning "SHIFT" (R1).

L. REJECTION FACTOR

- Set the below-mentioned knobs to the following positions:
 - "POLARITY" (SK2) to "NORMAL"

"POLARITY" (SK8) to "INVERT"
 "V/cm" (SK4-SK10) to ".01 V"
 "V/cm" (R3-R5) to "CAL."
 "DEFLECTION" (SK3-SK9) to "D.C."

The rejection factor must be greater than $100 \times$, and can be checked as follows.

- Set "MODE" (SK5) to "A" (B) and in both positions adjust the time-base line to the centre of the screen with "SHIFT" (R1) (R7).
- Adjust the sensitivity of channel A according to point "D".
- Apply simultaneously identical voltages of 100 mV_{p-p}, frequency 50 Hz, symmetrical around earthing level, to channels A and B.
Set "MODE" (SK5) to "ADDED."
- By means of "GAIN" (R6), adjust the sensitivity of channel B so, that the vertical deflection is minimum. The rejection factor exceeds $100 \times$, if the vertical deflection does not exceed 1 mm after this adjustment
- Increase the frequency of the input voltage to 1 MHz and repeat the abovementioned measurement.

M. TRIGGERING

- Set the belowmentioned knobs of the basic oscilloscope to the following positions:
 "TRIGG. MODE" to "H.F."
 "TRIGG. SLOPE" to "+"
 "TRIGG. SOURCE" to "INT."
 "STABILITY" to "PRESET"
- Set "MODE" (SK5) and "TRIGG." (SK6) to position A.
- Set "V/cm" (R3-R5) to "CAL."
- Apply a sine-wave voltage with a frequency of 10 MHz to channel A and adjust the trace height to 3 mm.
- With "LEVEL" (R2) on the basic-oscilloscope, a correctly triggered display should be obtained at this trace height.
- Set "TRIGG." (SK6) to "B."
The display should not remain triggered.
- Set "MODE" (SK5) and "TRIGG." (SK6) to position "B".
- Apply the voltage to channel B and check in the same way the triggering at a trace height of 3 mm.
- With "TRIGG." (SK6) to position "A", the display should not remain triggered.
- Decrease the frequency of the input voltage to 100 kHz and adjust the trace height to 40 mm.
- Check the trigger polarity on both channels.
With "POLARITY" (SK2 and SK8) to "NORMAL" time base A should start on the positive-going edge of the signal.
- Check that in position "ADDED" of "MODE"

(SK5), the trigger voltage is taken off via relay RE601.

For this, apply a voltage with a frequency of 100 kHz to channel A and with "LEVEL" of the basic oscilloscope, adjust for a triggered display.

- The triggering should not be affected by switching over "TRIGG." (SK6).
- With "POLARITY" (SK2 and SK7) to "NORMAL" time base A should start again on the positive-going edge of the signal.

N. CHOPPING

1. Frequency

- Set "MODE" (SK5) to position "CHOPPED".
In this position, two time-base lines should be written which can be shifted with respect to each other with "SHIFT" (R1 and R7).
- With "SHIFT" (R1-R7) adjust the distance between both time-base lines to approximately 5 cm.
- Both time-base lines should be periodically interrupted in the frequency of the switching voltage.
With SK11, at the right hand side of the unit, it should be possible to adjust the switching frequency to 20 kHz or 500 kHz.
- Check in both positions of SK11 the switching frequency by measuring the period time. For this, the basic oscilloscope should be triggered externally by a signal from terminal 2 of T501 at the dual trace unit (see Fig. 13). Apply this signal to "EXT." (BU1) of the basic oscilloscope and set "TRIGG. SOURCE" (SK3) to "EXT".
- In position 20 kHz of SK11, the period time should be between 40 and 60 μ sec., in position 500 kHz between 1.6 and 2.4 μ sec.

2. Blanking

- Trigger the basic oscilloscope externally with the switching voltage as indicated in point N1.
- Adjust the switching frequency to 500 kHz (SK11) and check the blanking. The blanking can be switched on with switch SK14 at the rear of the basic oscilloscope.
- Without blanking (SK14 to position "EXT."), the edges of the switching pulses are visible. When SK14 is set to position "MULTI-TRACE-CHOPPER", the edges should not be visible.

3. Ext. chopped

- Set "MODE" (SK5) to position "EXT. CHOPPED".
- Check that the chopper operates with an external driving voltage. For this, apply a symmetrical square-wave voltage with a frequency of 100 kHz

and a rise time of 25 nsec. to "EXT. CHOPPED" (BU2).

- With a peak-to-peak value of .9 V, the driver generator should operate and two time-base lines should be written.

O. ALTERNATE

- Set "MODE" (SK5) to position "ALTERNATE".
- Set time base A to its free-running position and adjust the time co-efficient to ".1 sec./cm".
- Check that the driver generator is switched over by the ALTERNATE pulse of time base A. In this case, two lines should be written.
As distinct from position "CHOPPED" these two time-base lines should be written continuously, but alternately after each other.
- Check this also if the time co-efficient of time base A has been adjusted to .05 μ sec.

Remark

In case of breakdown, one can always apply to the world-wide PHILIPS Service Organisation.

Whenever it is desired to send the apparatus to a PHILIPS Service Centre for repairs, the following points should be observed.

- tie on a label, bearing full name and address of the sender.
- indicate as complete as possible the symptom(s) of the fault(s).
- carefully pack the apparatus in the original packing, or, if no longer available, in a wooden crate.
- send the apparatus to the address provided by your local PHILIPS representative.

Parts list**A. MECHANICAL**

<i>Item</i>	<i>Fig.</i>	<i>Qty</i>	<i>Code number</i>	<i>Description</i>
1	6	1	4822 455 80043	Text plate
2	8	1	4822 265 60002	Connector
3	6	1	4822 273 50068	Switch SK5, 6
4	6	1	4822 290 40008	Terminal
5	6	3	4822 265 10004	Connector (BNC)
6	6	2	4822 277 20014	Sliding switch SK2, SK8
7	6	3	4822 413 40112	Knob, SK4, SK5, SK10
8	6	1	4822 413 30084	Knob, SK6
9	6	3	4822 413 70039	Cap
10	6	1	4822 413 30082	Knob, R1, R7
11	6	2	4822 413 70038	Cap
12	6	2	4822 413 30085	Knob, R3, R5
13	6	2	4822 413 30164	Push button, SK1, SK7
14	8	1	4822 216 50108	Unit 9, (Amplifier)
15	6	1	4822 216 50109	Unit 10, (Trigger ampl.)
16	6	1	4822 216 50102	Unit 12, (Dual trace.)
17	8	1	4822 216 50104	Unit 13, (Drift comp.)
18	8	1	4822 216 50114	Unit 14, (Amplifier).
19		1	4822 216 50113	Unit 11, (Final stage)
20	2	1	4822 277 20019	Sliding switch, SK11 (modified)

B. ELECTRICAL — ELEKTRISCH — ELEKTRISCH — ELECTRIQUE — ELECTRICOS



















This parts list does not contain multi-purpose and standard parts. These components are indicated in the circuit diagram by means of identification marks. The specification can be derived from the survey below.

Diese Ersatzteilliste enthält keine Universal- und Standard-Teile. Diese sind im jeweiligen Prinzipschaltbild mit Kennzeichnungen versehen. Die Spezifikation kann aus nachstehender Übersicht abgeleitet werden.

In deze stuklijst zijn geen universele en standaardonderdelen opgenomen. Deze componenten zijn in het prinsipschema met een merkteken aangegeven. De specificatie van deze merktekens is hieronder vermeld.

La présente liste ne contient pas des pièces universelles et standard. Celles-ci ont été repérées dans le schéma de principe. Leurs spécifications sont indiquées ci-dessous.

Esta lista de componentes no comprende componentes universales ni standard. Estos componentes están provistos en el esquema de principio de una marca. El significado de estas marcas se indica a continuación.

	Carbon resistor E24 series Kohleschichtwiderstand, Reihe E24 Koolweerstand E24 reeks Résistance au carbone, série E24 Resistencia de carbón, serie E24	} 0,125 W	5%		Carbon resistor E12 series Kohleschichtwiderstand, Reihe E12 Koolweerstand E12 reeks Résistance au carbone, série E12 Resistencia de carbón, serie E12	} 1	$W \leq 2,2 \text{ M}\Omega$, 5% $> 2,2 \text{ M}\Omega$, 10%
	Carbon resistor E12 series Kohleschichtwiderstand, Reihe E12 Koolweerstand E12 reeks Résistance au carbone, série E12 Resistencia de carbón, serie E12	} 0,25 W $\leq 1 \text{ M}\Omega$, 5% $> 1 \text{ M}\Omega$, 10%			Carbon resistor E12 series Kohleschichtwiderstand, Reihe E12 Koolweerstand E12 reeks Résistance au carbone, série E12 Resistencia de carbón, serie E12	} 2	W 5%
	Carbon resistor E24 series Kohleschichtwiderstand, Reihe E24 Koolweerstand E24 reeks Résistance au carbone, série E24 Resistencia de carbón, serie E24	} 0,5 W $\leq 5 \text{ M}\Omega$, 1% $> 5 \text{ M}\Omega$, 2% $> 10 \text{ M}\Omega$, 5%			Wire-wound resistor Drahtwiderstand Draadgewonden weerstand Résistance bobinée Resistencia bobinada	} 0,4 – 1,8 W	0,5%
	Carbon resistor E12 series Kohleschichtwiderstand, Reihe E12 Koolweerstand E12 reeks Résistance au carbone, série E12 Resistencia de carbón, serie E12	} 0,5 W $\leq 1,5 \text{ M}\Omega$, 5% $> 1,5 \text{ M}\Omega$, 10%			Wire-wound resistor Drahtwiderstand Draadgewonden weerstand Résistance bobinée Resistencia bobinada	} 5,5 W $\leq 200 \Omega$, 10% $> 200 \Omega$, 5%	
					Wire-wound resistor Drahtwiderstand Draadgewonden weerstand Résistance bobinée Resistencia bobinada	} 10 W	5%
	Tubular ceramic capacitor Rohrkondensator Keramische kondensator, buistype Condensateur céramique tubulaire Condensador cerámico tubular	} 500 V			Polyester capacitor Polyesterkondensator Polyesterkondensator Condensateur au polyester Condensador polyester	} 400 V	
	Tubular ceramic capacitor Rohrkondensator Keramische kondensator, buistype Condensateur céramique tubulaire Condensador cerámico tubular	} 700 V			Flat-foil polyester capacitor Miniatur-Polyesterkondensator (flach) Platte miniatuur polyesterkondensator Condensateur au polyester, type plat Condensador polyester, tipo de placas planas	} 250 V	
	Ceramic capacitor, "pin-up" Keramikkondensator "Pin-up" (Perltyp) Keramische kondensator "Pin-up" type Condensateur céramique, type perle Condensador cerámico, versión "colgable"	} 500 V			Paper capacitor Papierkondensator Papierkondensator Condensateur au papier Condensador de papel	} 1000 V	
	"Microplate" ceramic capacitor Miniatur-Scheibenkondensator "Microplate" keramische kondensator Condensateur céramique "microplate" Condensador cerámico "microplaca"	} 30 V			Wire-wound trimmer Drahttrimmer Draadgewonden trimmer Trimmer à fil Trimmer bobinado		
	Mica capacitor Glimmerkondensator Micakondensator Condensateur au mica Condensador de mica	} 500 V			Tubular ceramic trimmer Rohrtrimmer Buisvormige keramische trimmer Trimmer céramique tubulaire Trimmer cerámico tubular		



For multi-purpose and standard parts, please see PHILIPS' Service Catalogue.

Für die Universal- und Standard-Teile siehe den PHILIPS Service-Katalog.

Voor universele en standaardonderdelen raadplege men de PHILIPS Service Catalogue.

Pour les pièces universelles et standard veuillez consulter le Catalogue Service PHILIPS.

Para piezas universales y standard consulte el Catálogo de Servicio PHILIPS.

<i>Number</i>	<i>Code number</i>	<i>Value</i>	<i>Watts</i>	<i>%</i>	<i>Description</i>
R1,7	4822 102 30066	2 × 20 kΩ			Duo potentiometer
R2,8	4822 100 20003	470 Ω			Potentiometer
R3,5	4822 100 20005	50 Ω			Potentiometer
R4,6	4822 100 20006	300 Ω			Potentiometer
R28,128	4822 110 30072	47 Ω	0.1	1	Carbon
R29,129	4822 111 20143	500 kΩ	0.1	1	Carbon
R31,131	4822 111 20121	1 MΩ	0.1	1	Carbon
R32,132	4822 111 20147	800 kΩ	0.1	1	Carbon
R33,133	4822 111 20117	260 kΩ	0.1	1	Carbon
R34,134	4822 111 20148	900 kΩ	0.1	1	Carbon
R36,136	4822 111 20115	111 kΩ	0.1	1	Carbon
R37,137	4822 111 20149	950 kΩ	0.1	1	Carbon
R38,138	4822 111 20136	52.6 kΩ	0.1	1	Carbon
R39,139	4822 111 20151	980 kΩ	0.1	1	Carbon
R41,141	4822 111 20109	20.4 kΩ	0.1	1	Carbon
R42,142	4822 111 20152	990 kΩ	0.1	1	Carbon
R43,143	4822 111 20107	10.1 kΩ	0.1	1	Carbon
R44,144	4822 111 20237	995 kΩ	0.1	1	Carbon
R46,146	4822 111 20238	5.03 kΩ	0.1	1	Carbon
R47,147	4822 111 20239	998 kΩ	0.1	1	Carbon
R48,148	4822 110 30115	2 kΩ	0.1	1	Carbon
R49,149	4822 111 20121	1 MΩ	0.1	1	Carbon
R51,151	4822 110 30107	1 kΩ	0.1	1	Carbon
R205,305	4822 111 20121	1 MΩ	0.1	1	Carbon
R213,313	4822 103 20092	2.2 kΩ	3.3		Potentiometer
R235-335	902/A...	(1.5 kΩ)	0.125	5	Choice resistor
R254,254	4822 116 50167	150 Ω	0.125	1	Metal film
R246,356	4822 116 50166	150 Ω	0.125	1	Metal film
R261,361	4822 116 50168	6,8 Ω	0.25	1	Metal film
R263,363	902/A...	(3.6 kΩ)	0.125	5	Choice resistor
R264,364	4822 116 50168	6.8 kΩ	0.25	1	Metal film
R605	4822 101 20073	1 kΩ			Potentiometer
R623	902/K...	(2.2 kΩ)	0.5	5	Choice resistor

CAPACITORS

<i>Number</i>	<i>Code number</i>	<i>Value</i>	<i>Volts</i>	<i>Description</i>
C26,126	4822 121 20083	100 nF	600	Paper
C28,128	904/P	(2.7 pF)	500	Choice capacitor (cer.)
C29,129	4822 125 60045	68 pF		Trimmer (cer.)
C33...36	4822 125 60045	68 pF		Trimmer (cer.)
C38, 39	4822 125 60045	68 pF		Trimmer (cer.)
C41,141	4822 123 10165	27 pF	300	Mica
C44,144	4822 123 10166	56 pF	300	Mica
C48,148	4822 123 10167	150 pF	300	Mica
C42...51	4822 125 60045	68 pF		Trimmer (cer.)
C52,152	4822 123 10168	300 pF	300	Mica
C56,156	4822 123 10169	600 pF	300	Mica
C59,159	4822 123 10171	1500 pF	300	Mica
C53...62	4822 125 60045	68 pF		Trimmer (cer.)
C63,163	4822 123 10172	2400 pF	300	Mica
C133...136	4822 125 60045	68 pF		Trimmer (cer.)
C138,139	4822 125 60045	68 pF		Trimmer (cer.)
C142...151	4822 125 60045	68 pF		Trimmer (cer.)
C153...162	4822 125 60045	69 pF		Trimmer (cer.)
C201,202	4822 121 40029	10 nF	250	Polyester
C204,304	4822 121 40059	100 nF	250	Plate capacitor
C206,306	4822 121 40029	10 nF	250	Polyester
C208,308	4822 121 40056	56 nF	250	Plate capacitor
C211,311	904/...	390 pF	500	Choice capacitor
C213,313	4822 121 40059	100 nF	250	Plate capacitor
C214,314	4822 121 40047	10 nF	250	Plate capacitor
C217,317		(39 nF)	250	Polyester; choice cap.
C218,318	904/...	12 pF	500	Choice capacitor
C221,321	4822 121 40059	100 nF	250	Plate capacitor
C302	4822 121 40029	10 nF	150	Polyester
C401	904/...	(39 pF)	500	Choice capacitor
C404,407	4822 121 40059	100 nF	250	Plate capacitor
C408	4822 121 40036	100 nF	500	Polyester
C409,413	909/G 6.4	6.4 μ F	150	Electrolytic
C422	904/...	2.7 pF	500	Choice capacitor
C503,504	4822 121 40036	100 nF	500	Polyester
C508	4822 121 40047	10 nF	250	Plate capacitor
C513	4822 121 40036	100 nF	500	Polyester
C514,515	4822 121 40059	100 nF	250	Plate capacitor
C604,606	4822 121 40036	100 pF	500	Polyester

COILS, RELAYS, TRANSFORMERS

<i>Number</i>	<i>Code number</i>	<i>Qty</i>	<i>Description</i>
L1, 101, 201 L202, 301, 302	4822 562 10025	6	Bead
L401...408	4822 158 10038	8	Coil
RE601	4822 280 80234	1	Relay
TS01	4822 157 50182	1	Transformer

SEMICONDUCTORS

<i>Number</i>	<i>Type</i>	<i>Qty</i>	<i>Description</i>
GR201,206,301,306, GR202,203,204,208,209 GR211,212,302,303,304 GR308,311,312,501, GR502,503	BAX16 BAY38	4 16	Silicon diode Silicon diode
GR207,307 GR401,401 GR504,506,507,508	BZY61 BZY68 AAZ17	2 2 4	Zener diode Silicon diode Germanium diode
TS201...402 TS403...409 TS606...609	AFZ12*) BFY90 BC107	 6 4	Transistor Transistor Transistor
TS501 TS502 TS503,504. TS602...605	AF124 ASZ21 BSY39 BSY38	1 1 2 4	Transistor Transistor Transistor Transistor

VALVES

<i>Number</i>	<i>Type</i>	<i>Qty</i>	<i>Description</i>
B201,202,301,302. (should be selected for minimum hum, noise and microphony) Service code: 4822 131 10008.	EC1000	4	Triode

Note: * Transistors TS203, TS204, TS303, TS304 should be selected for a $h_{fe} \geq 100$ at $I_C = 4$ mA and $V_{CE} \cong 3.5$ V.
TS203-TS204 and TS303-TS304 should be matched having a V_{BE} equal within 5 mV.

Transistors TS206, TS207, TS306, TS307 should be selected for a $h_{fe} \geq 70$ at $I_C = 4$ mA and $V_{CE} \cong 4.5$ V.
TS206-TS207 and TS306-TS307 should be matched having a V_{BE} equal within 5 mV.

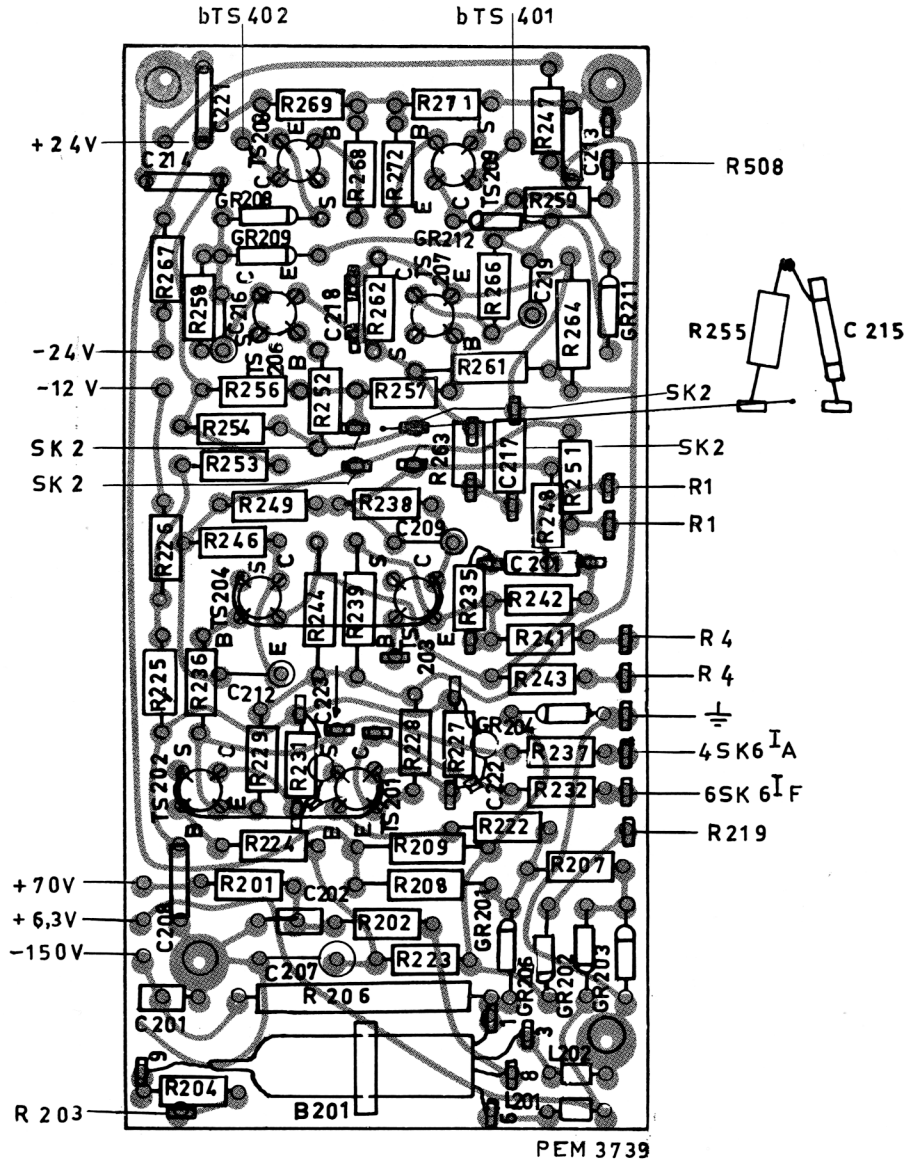

Fig. 11. Amplifier, channel A

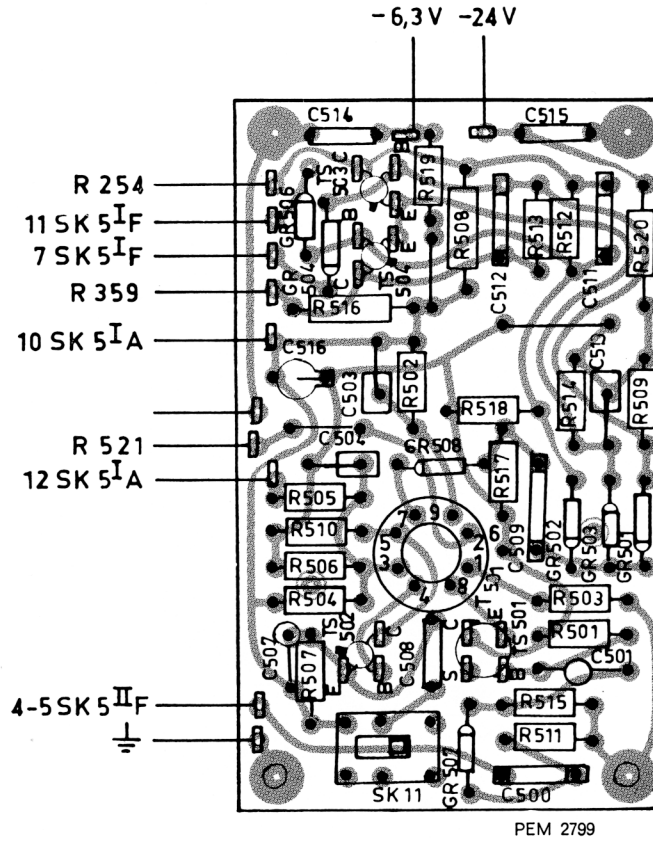

Fig. 13. Dual-trace unit

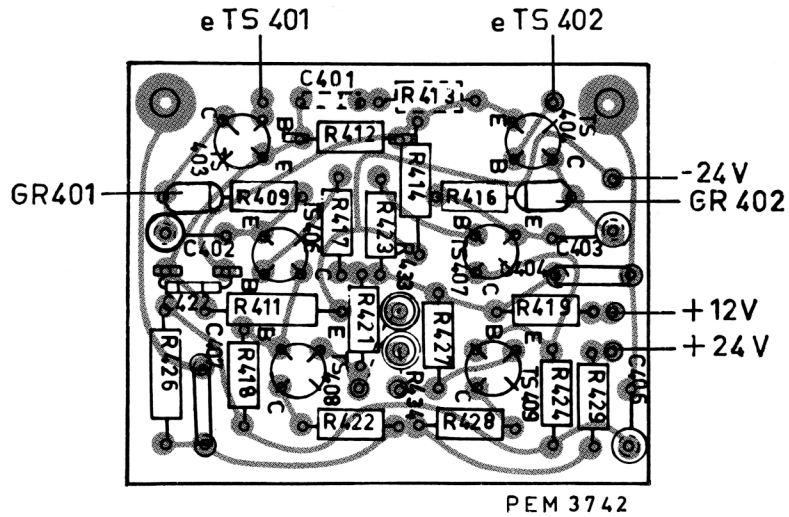

Fig. 14. Output amplifier

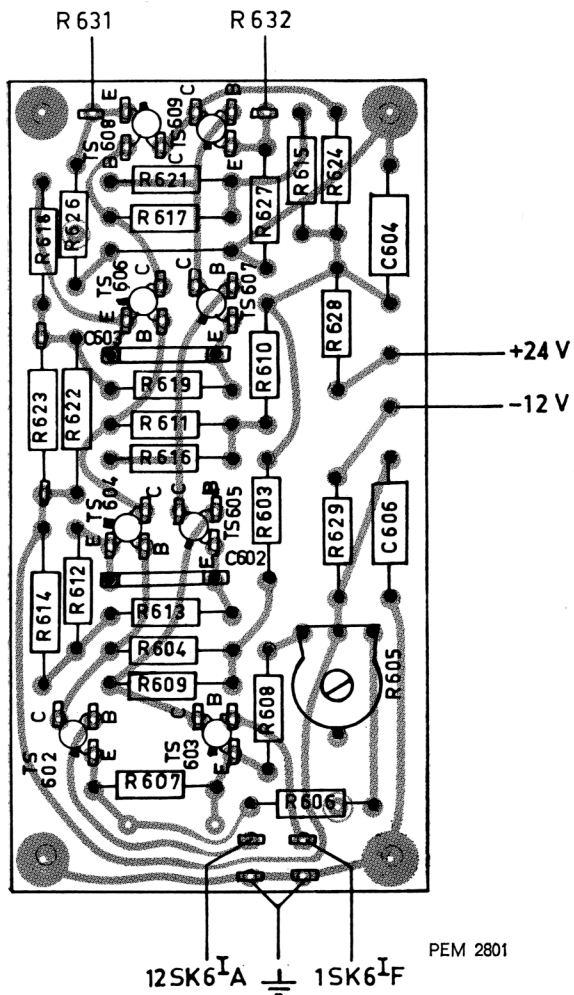

Fig. 15. Trigger amplifier

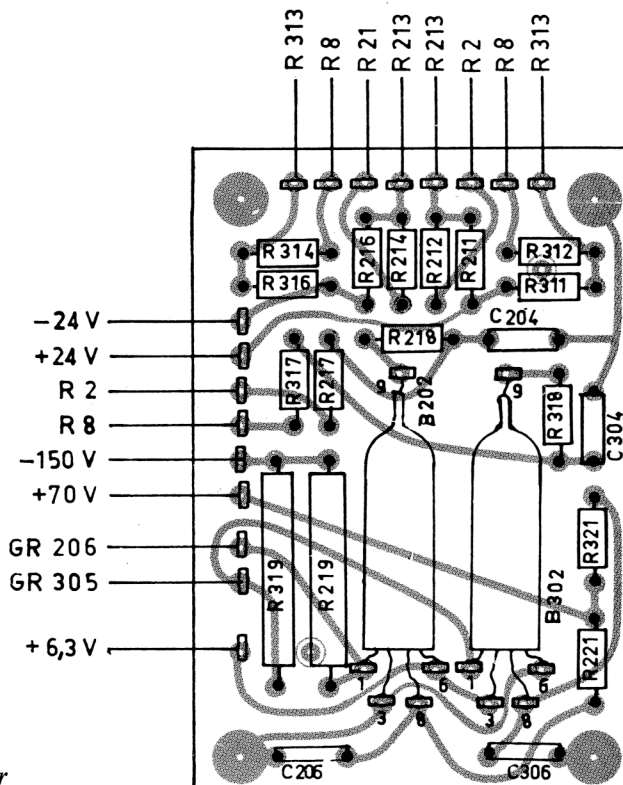

Fig. 16. Drift compensator

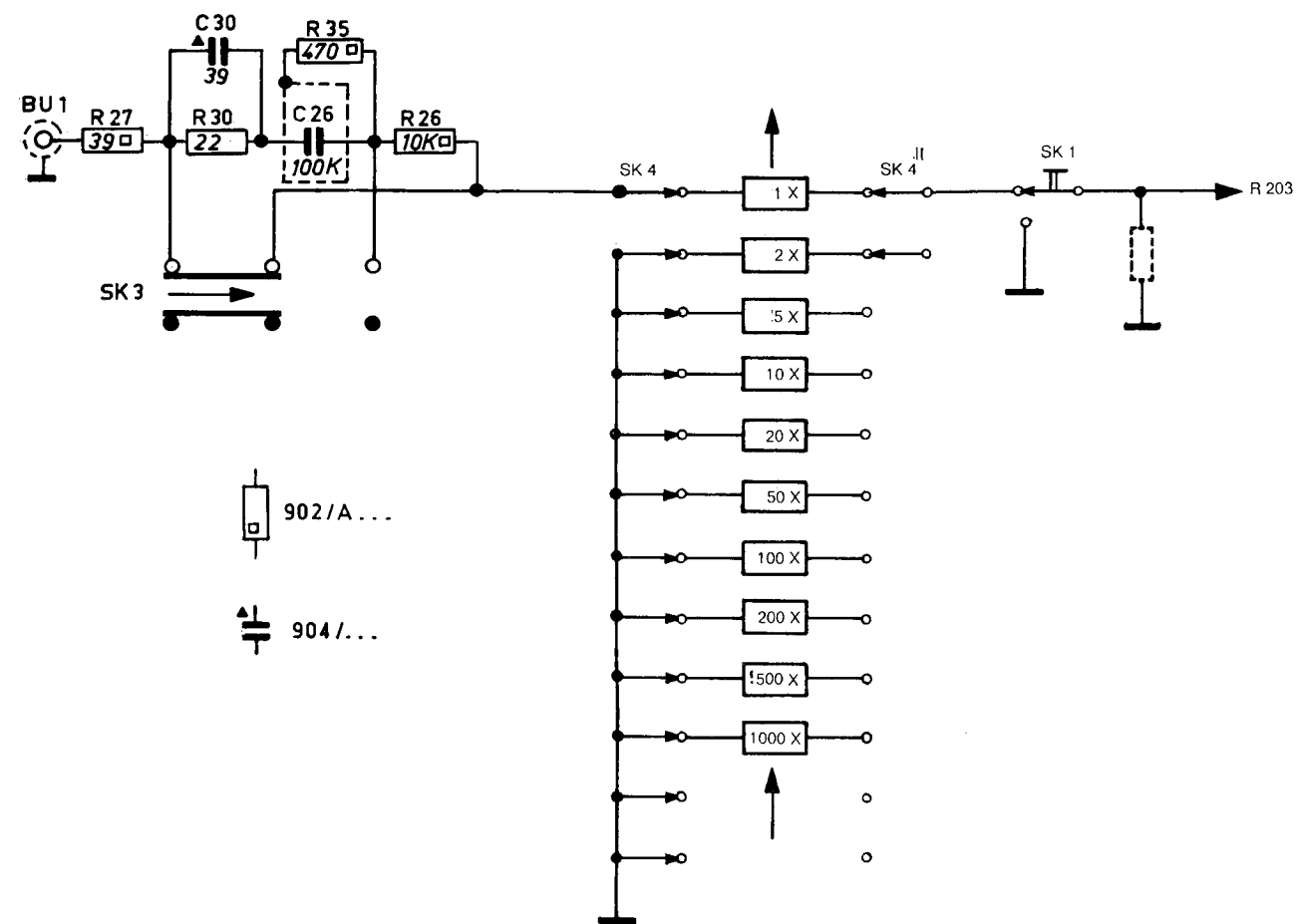
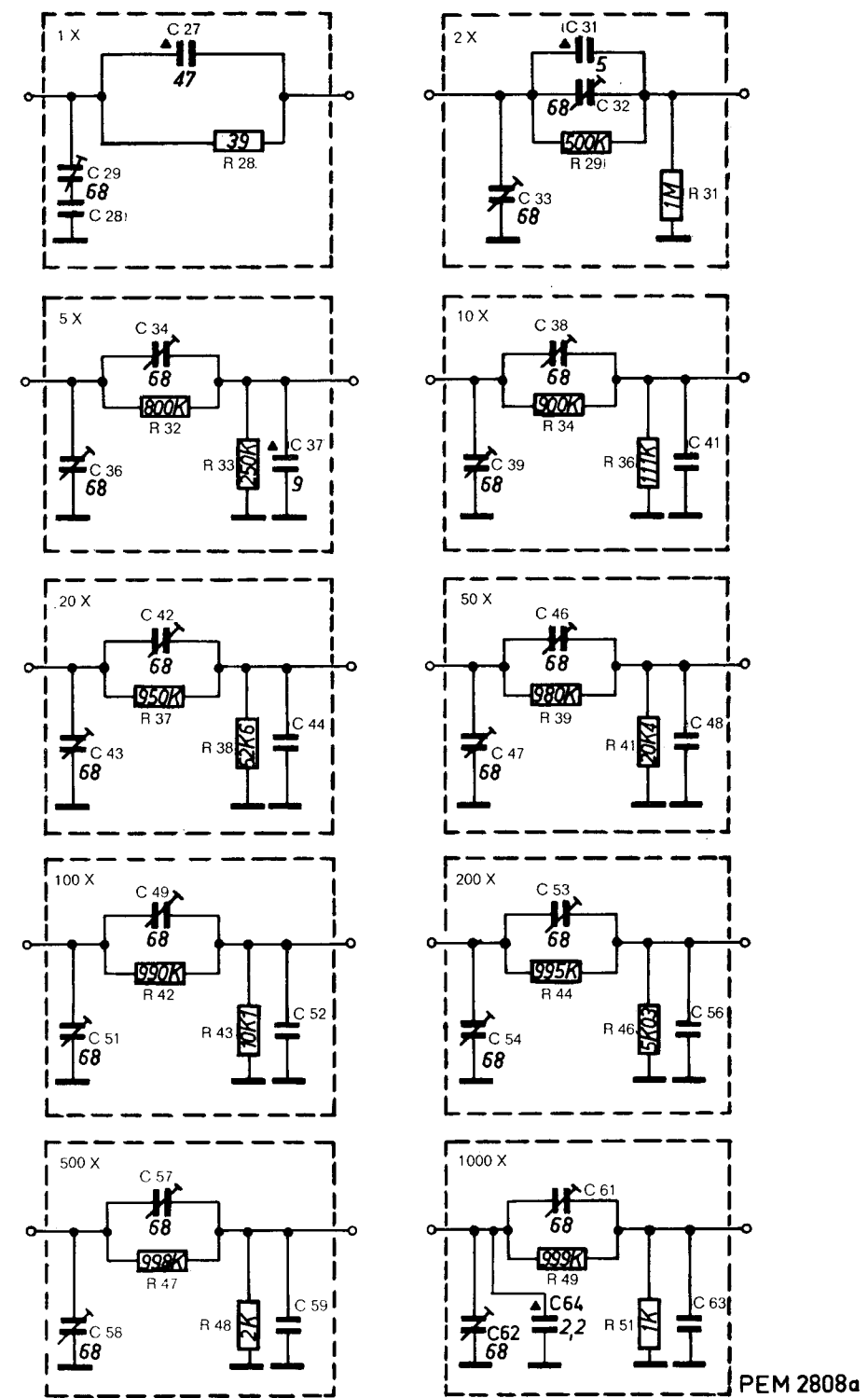

Fig. 17. Attenuator, channel A

Erratum: C30 scrapped



PEM 2808a

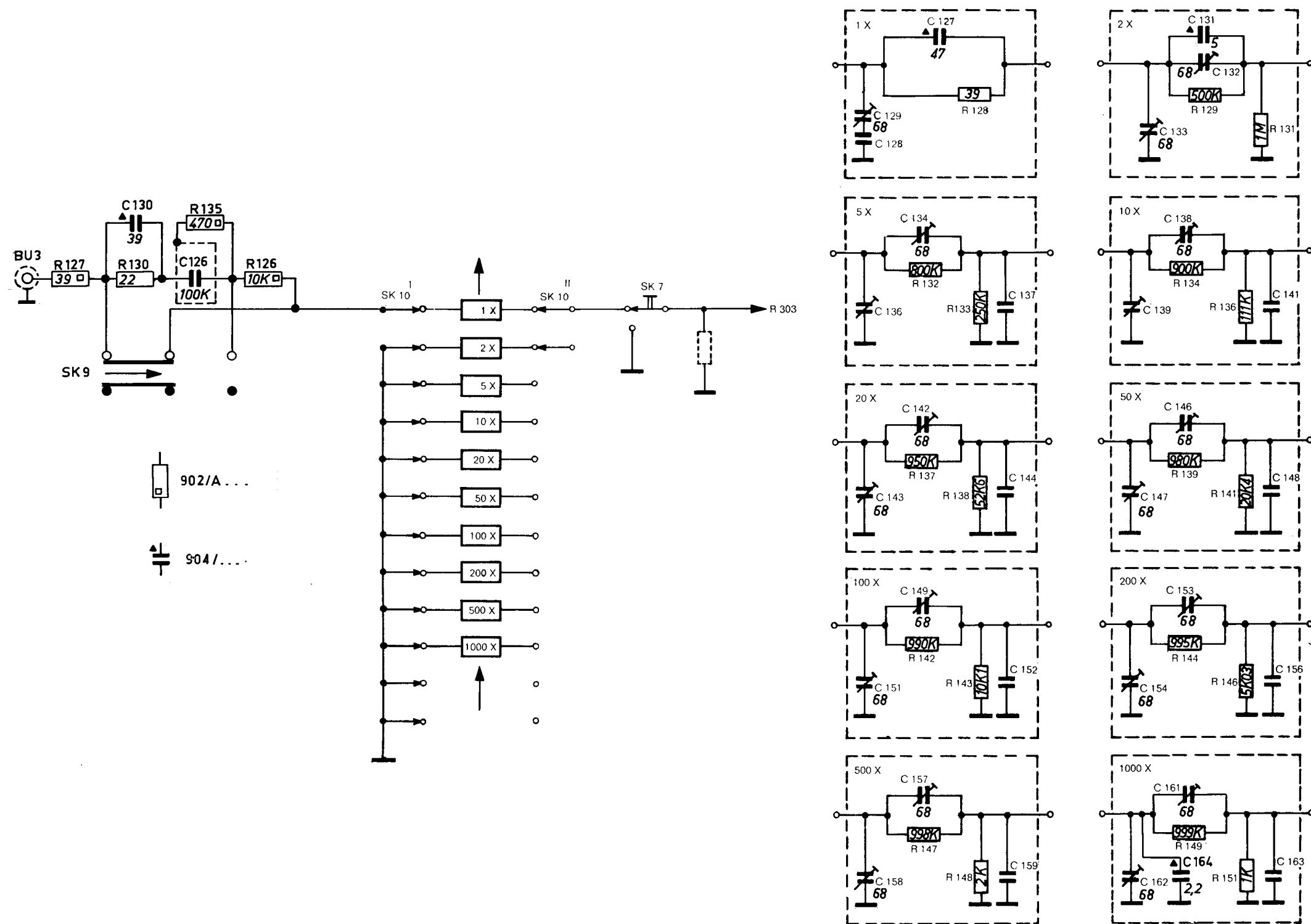

Fig. 18. Attenuator, channel B

Erratum: C130 scrapped

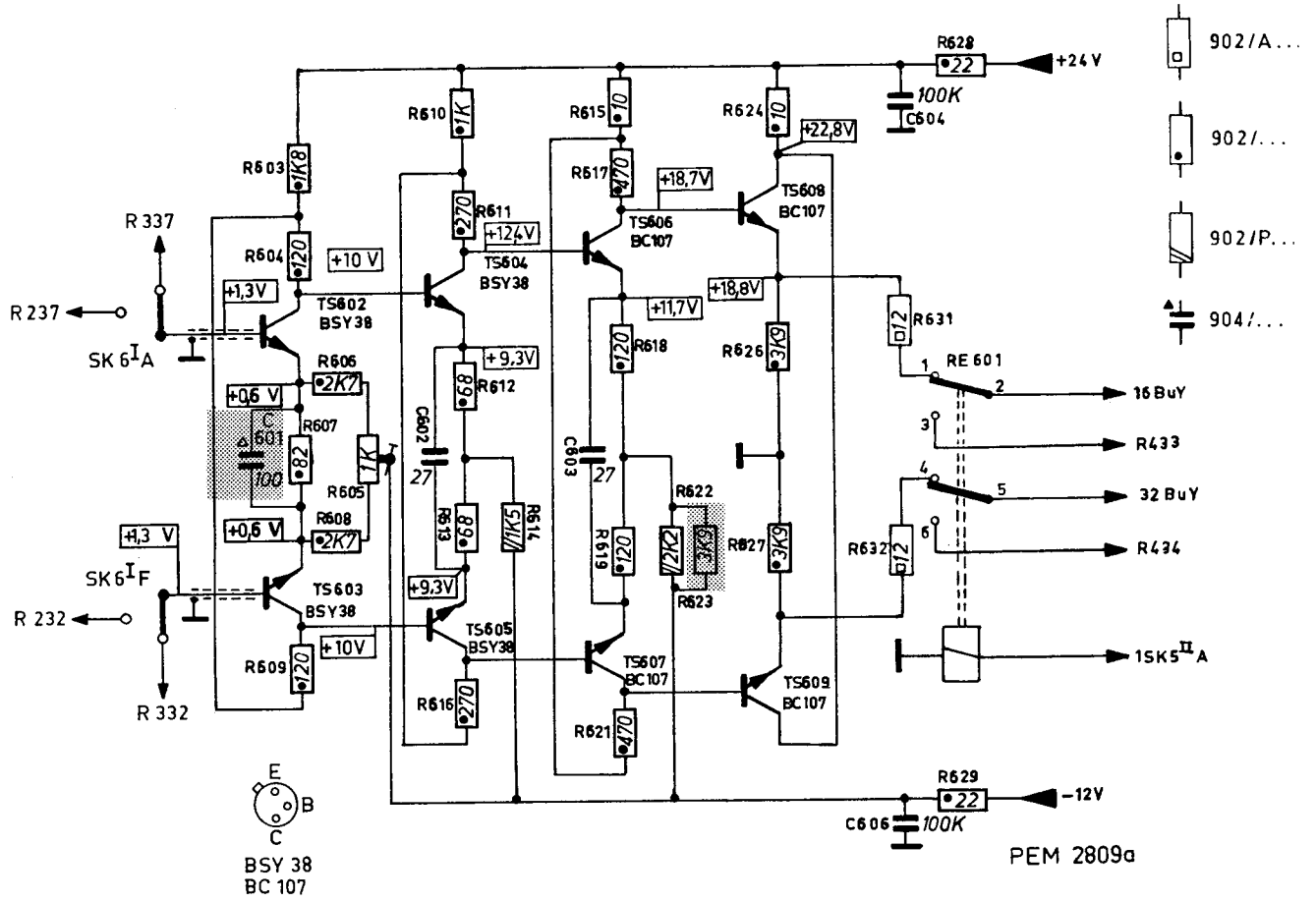
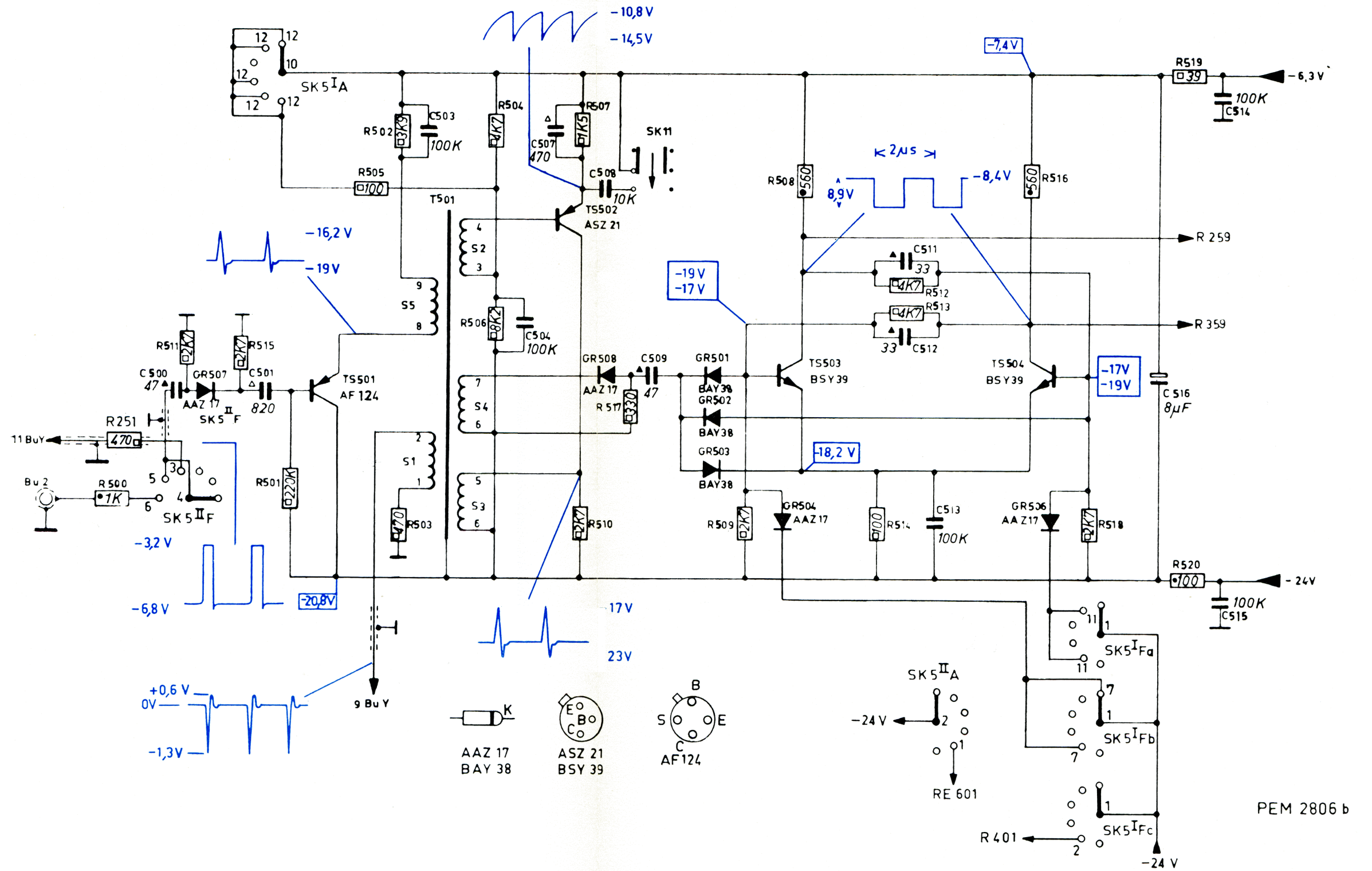

Fig. 19. Trigger-amplifier circuit



PEM 2806 b

Fig. 20. Dual-trace circuit

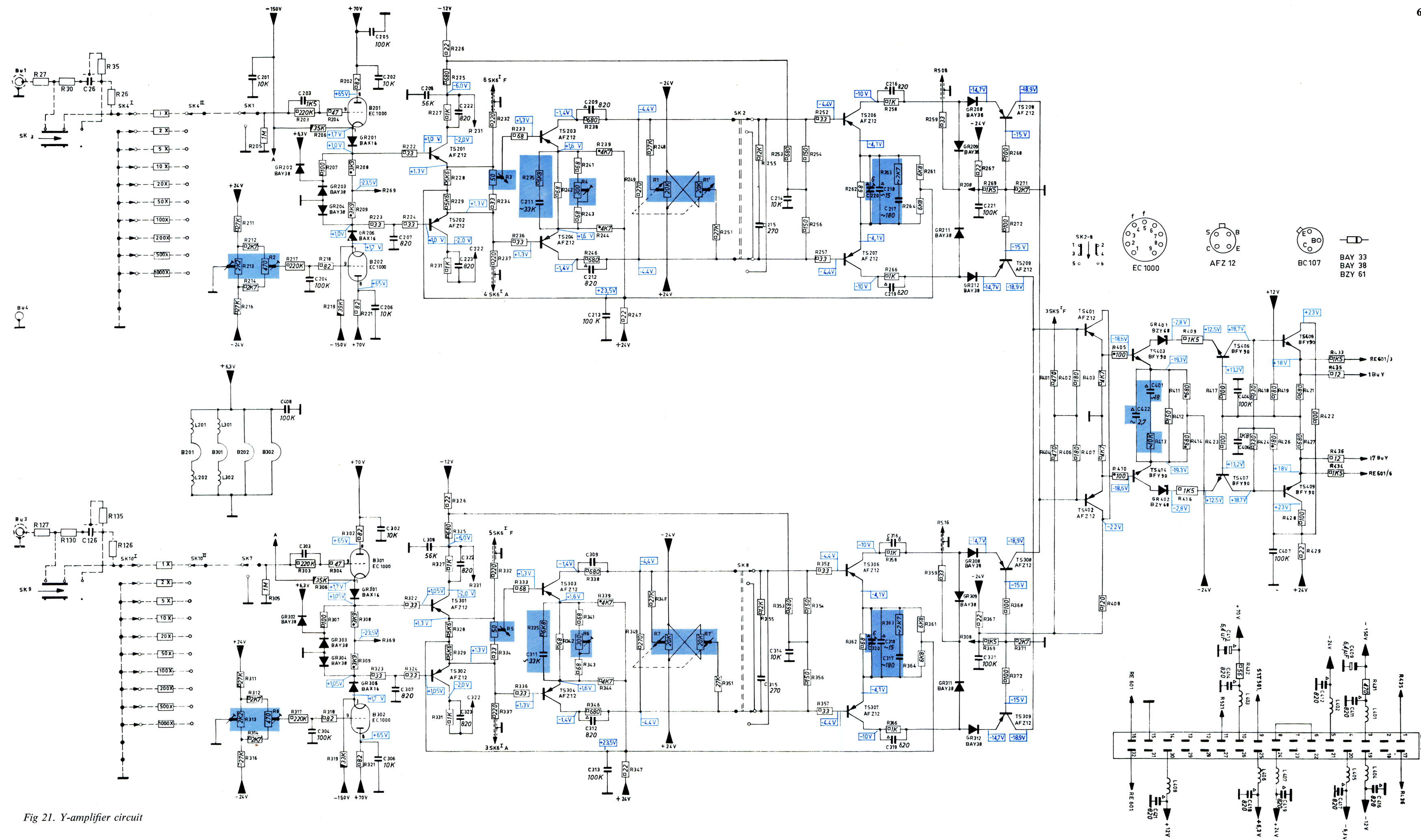

Fig 21. Y-amplifier circuit

1-2-1969	PM 3342/04/05	Cd 608
----------	---------------	--------

P.I.T.-SERVICE

Versions PM 3342/04 and PM 3342/05 are equal to the -/03 version with the exception of the following changes:

1. To facilitate the HF square-wave response adjustments at channel A and channel B, capacitors C 218 and C 318 have been given a fixed value of 15 pF. The adjustments are carried out by trimmers C 220 and C 320 respectively, which are connected parallel to them.
2. To increase the stability of the final stage, the value of R 405 and R 410 has been increased to 100 Ω (33 Ω).

Note: – the following changes were already introduced into the -/03 version.

1. The value of R 233 and R 333 has been increased to 68 Ω (33 Ω)
2. R 201 and R 301 have been short-circuited.

– if, in the parts list, C 503, 504 were denoted 100 pF, it should be 100 nF
and if C 508 was denoted 10 pF, it should be 10 nF

A revised circuit diagram has been added instead of Fig. 21.

Mit Ausnahme folgender Änderungen entsprechen die Ausführungen PM 3342/04 und PM 3342/05 der -/03-Ausführung.

1. Um die Einstellungen der HF-Rechteckwiedergabe an Kanal A und Kanal B zu erleichtern erhielten die Kondensatoren C 218 und C 318 einen Festwert von 15 pF. Die Einstellungen werden von den parallel zu den Kondensatoren geschalteten Trimmern C 220 und C 320 vorgenommen.
2. Zur Steigerung der Stabilität der Endstufe ist der Wert von R 405 und R 410 in 100 Ω (33 Ω) geändert worden.

Bemerkung: – Folgende Änderungen wurden bereits in der -/03- Ausführung vorgenommen:

1. der Wert von R 233 und R 333 wurde auf 68 Ω erhöht
2. R 201 und R 301 wurden kurzgeschlossen

– in der Ersatzteilliste wurden C 503, 504 mit 100 pF bezeichnet; dies ist jedoch in 100 nF zu ändern;
C 508 wurde mit 10 pF bezeichnet, was in 10 nF zu ändern ist.

Ein revidiertes Schaltbild ersetzt Abb. 21.

Les versions PM 3342/04 et PM 3342/05 sont identiques au -/03, à l'exception des points suivants:

1. Afin de faciliter les ajustements aux canaux A et B de la réponse d'onde rectangulaire HF, on donne aux capacités C 218 et C 318 une valeur fixe de 15 pF. Ces ajustements sont réalisés par les trimmers C 220 et C 320 en parallèles avec les capacités.
2. Pour obtenir une stabilité plus grande de l'étage de sortie on a mis R 405 et R 410 à 100 Ω (33 Ω).

N.B. – Les changements suivants ont également été apportés dans la version -/03.

1. R 233 et R 333 sont mis à 68 Ω (33 Ω).
2. R 201 et R 301 ont été court-circuitées.

– dans la nomenclature, pour C 503, 504, il est marqué 100 pF; cela doit être 100 nF
et pour C 508 il est marqué 10 pF; cela doit être 10 nF.

Un diagramme de circuit révisé a été ajouté en remplacement de la fig. 21.

SERVICE

Electron optics / Nuclear and electrochemical
equipment / X-Ray analysis / Cryogenic
equipment / Test and measuring equipment /
Process instrumentation /
Industrial Data Processing Systems /
Weighing / Welding / Numerical Control /
Textile equipment

industrial equipment division



15-4-1969

PM 3342/05

Cd 620

TEST AND MEASURING EQUIPMENT

Contrary to service information Cd 608, dual trace plug in unit PM 3342/05 obtained during manufacture FET-input circuits to minimise DC-drift. They are incorporated in 2 printed circuits, replacing the EC 1000 cathode-followers and compensating tubes previously used. The printed circuits are separately available for modernising old type plug-ins (see enclosed instructions.)

Further changes are:

1. C401 is replaced by a 6 pF trimmer paralleled by a 6.2 pF cer. capacitor.
2. The value of R238, R246, R338 and R346 has been changed to 510 Ω .
3. The value of R242 and R342 (68 Ω) has been changed to 82 Ω
4. The value of R419 (180 Ω) has been changed to 56 Ω .
5. Capacitors C205 and C305 have been added; C213 and C313 have been removed. The value of R252, R257, R352, R357 (33 Ω) has been changed to 120 Ω ; the value of R242 and R342 (68 Ω) has been changed to 82 Ω .

No changes were made in the specifications or in the adjustment procedure. A revised dual trace circuit (fig. 20) and Y-amplifier circuit (fig. 21) have been added.

FET INPUT UNIT
FOR DUAL-TRACE PM 3342

Make the following changes for channel A (For channel B select the corresponding parts).

- a. At the decoupling unit near the 32 pole plug: remove the connection of the -150 V supply and load the +6,3 V supply with 10 Ω (10 W) at the drift-compensator print.
- b. Remove the connections of the 2 mentioned supplies from the decoupling unit to the amplifier prints.
- c. At the amplifier print, channel A: remove the -150 V supply and the +6.3 V supply, and connect C205 (68 nF; plate) between connection C223/R231/c TS202 and earth (C208). Remove B201, GR201, GR202, GR203, GR204, GR206 and R201, R202, R204, R206, R207, R208, R209, R219, R223, L201, L202, C201, C202, C207, C213.
- d. At the drift-compensator print: remove B202 and interconnect "1" and "9". Remove R219 and R319. Change R211 and R216 for resistors 6800 Ω 1/8 W 5 %.
- e. Mount the FET-unit, using two 3-mm metal spacers and connect it according to the circuit diagram shown below.
- f. Plug the DUAL-TRACE Unit into the basic oscilloscope. Balance according to chapter XI B1 and B2, and check the square wave response according to F1 and F2.
- g. BFW11 to be selected at $I_D \approx 2.5$ mA, $V_{DS} \approx 9$ V for $V_{GS} \approx 1.7$ V

Note: 1. for channel B it is advisable to use a mirrored layout of the circuit.

2. it is recommended to replace C401 by a trimmer 6 pF//5.6 or 12 pF cer.
3. change the value of R238, R246, R338, R346, to 510 Ω and the value of R252, R257, R352, R357 to 120 Ω .
4. change the value of R242, R342 to 82 Ω

Im Widerspruch zu Service-Mitteilung Cd 608, wurde dem 2-Kanal-Einschub PM 3342/05 während der Herstellung Feldeffekt-Eingangsschaltungen hinzugefügt, um die Gleichspannungsdrift auf das Mindestmass zurückzuführen.

Die Schaltungen sind auf zwei Leiterplatten angeordnet und ersetzen die Katodenfolger EC 1000 und die vorher benutzten Kompensationsröhren.

Zum Modernisieren der bisherigen Einschübe (siehe beiliegende Vorschriften) sind diese Leiterplatten gesondert erhältlich.

Weitere Änderungen:

1. C401 ist durch einen, von einem 6,2-pF-Keramikkondensator parallelgeschalteten, 6-pF-Trimmerkondensator ersetzt worden
2. Der Wert von R238, R246, R338 und R346 ist in 510 Ω geändert worden
3. Der Wert von R242 und R342 (68 Ω) ist in 82 Ω geändert worden
4. Der Wert von R419 (180 Ω) ist in 56 Ω geändert worden
5. Die Kondensatoren C205 und C305 sind hinzugefügt worden, während C213 und C313 entfallen sind. Der Wert von R252, R257, R352 und R357 (33 Ω) ist in 120 Ω geändert worden, während der Wert von R242 und R342 (68 Ω) in 82 Ω geändert worden ist.

In den Spezifikationen und im Abgleich wurden keine Änderungen vorgenommen. Eine revidierte 2-Kanal-Schaltung (Abb. 20) und Y-Verstärker-Schaltung (Abb. 21) sind hinzugefügt worden.

FELDEFFEKT-EINGANGSSCHALTUNG FÜR 2-KANAL-EINSCH

Für Kanal A folgende Änderungen vornehmen (für Kanal B sind die entsprechenden Teile zu selektieren).

- a. An der Entstöreinheit neben dem 32poligen Stecker: Anschluss der -150-V-Speisung entfernen und +6,3-V-Speisung auf der Driftkompensatorprintplatte mit 10 Ω (10 W) belasten
- b. Anschlüsse der 2 erwähnten Speisungen zwischen der Entstöreinheit und den Verstärkerleiterplatten entfernen.
- c. Auf der Verstärkerleiterplatte, Kanal A: -150-V-Speisung und +6,3-V-Speisung entfernen und C205 (68 nF; Platte) zwischen Anschluss C223/R231/c TS202 und Masse (C208) anschliessen.
Folgende Teile entfernen: B201, GR201, GR202, GR203, GR204, GR206 und R201, R202, R204, R206, R207, R208, R209, R219, R223, L201, L202, C201, C202, C207 und C213.
- d. Am Driftkompensatorleiterplatte B202 entfernen und "1" und "9" miteinander verbinden. R219 und R319 entfernen, R211 und R216 für Widerstände 6800 Ω 1/8 W, 5 % ändern.
- e. Feldeffekt-Eingangsschaltung gemäss nachstehendem Schaltbild montieren und hierbei zwei Metallabstandshalter (Höhe = 3mm.) verwenden
- f. 2-Kanal-Einschub in das Grundgerät einsetzen. Gemäss Abschnitt XI, B1 und B2 Gleichspannungssymmetrie einstellen und Sprungcharacteristic gemäss F1 und F2 kontrollieren
- g. BFW11 auszuwählen für $V_{DS} \approx 1,7$ V bei $I_D \approx 2,5$ mA und $V_{DS} \approx 9$ V.

- Anm.: 1. Es empfiehlt sich, für Kanal B ein gespiegeltes Layout der Schaltung zu benutzen
2. Weiter ist es empfehlenswert, C401 durch einen 6-pF-Trimmerkondensator unter Nebenschluss eines 5,6 oder 12-pF-Keramikkondensators zu ersetzen
 3. Wert von R238, R246, R338, R346 in 510 Ω und den von R252, R257, R352, R357 in 120 Ω ändern
 4. Wert von R242, R342 in 82 Ω ändern.

Contrairement à la communication de service Cd 608, le tiroir 2 voies PM 3342/05 est, pendant la production équipé de circuits d'entrée à effet de champ, lesquels diminuent la dérive c.c. Ils sont incorporés dans les circuits imprimés et remplacent les tubes cathodines EC 1000 et les tubes de de compensation précédemment utilisés.

Les circuits imprimés peuvent être obtenus séparément; ils servent à moderniser les anciens types de tiroirs (voir instructions ci-jointes).

Autres changements:

1. C401 est remplacé par un trimmer 6 pF commuté en parallèle avec un condensateur céramique 6.2 pF.
2. La valeur de R238, R246, R338 et R346 est changée en 510 Ω .
3. La valeur de R242 et R342 (68 Ω) est changée en 82 Ω .
4. La valeur de R419 (180 Ω) est changée en 56 Ω .
5. Les condensateurs C205 et C305 sont ajoutés; C213 et C313 sont éliminés. La valeur de R252, R257, R352, R357 (33 Ω) est changée en 120 Ω . La valeur de R242 et R342 (68 Ω) est changée en 82 Ω .

Aucun changement n'est apporté dans les spécifications et dans le réglage. Un circuit 2 voies révisé (fig. 20) et un circuit d'amplificateur Y (fig. 21) sont ajoutés.

UNITE D'ENTREE A EFFET DE CHAMP POUR LE PM 3342

Réaliser les changements suivants dans le canal A (choisir les parties correspondantes pour le canal B).

- a. A l'unité de découplage près de la fiche à 32 pôles: enlever la connexion de l'alimentation -150 V et charger l'alimentation +6,3 V avec 10 Ω (10 W) sur la platine de compensateur de dérive.
- b. Enlever les connexions des deux alimentations mentionnées allant de l'unité de découplage aux platines d'amplificateur.
- c. Sur la platine d'amplificateur, canal A: enlever l'alimentation -150 V et l'alimentation +6,3 V et connecter C205 (68 nF; type plat) entre la connexion C223/R231/c TS202 et la masse (C208).
Enlever B201, GR201, GR202, GR203, GR204, GR206 et R201, R202, R204, R206, R207, R208, R209, R219, R223, L201, L202, C201, C202, C207, C213.
- d. Sur la platine de compensateur de dérive: enlever B202 et interconnecter "1" et "9". Enlever R219 et R319. Changer R211 et R216 pour les résistances 6800 Ω 1/8 W 5 %.
- e. Monter l'unité à effet de champ en utilisant deux entretoises métalliques (hauteur 3 mm) et la connecter selon le diagramme de circuit ci-dessous.
- f. Enficher le tiroir 2 voies dans l'oscilloscope de base. L'équilibrer selon B1 et B2 du chapitre XI et contrôler la réponse d'onde rectangulaire selon F1 et F2.
- g. BFW11 à sélectionner pour $V_{GS} \approx 1,7$ V à $I_D \approx 2,5$ mA et $V_{DS} \approx 9$ V.

N.B.: 1. Pour le canal B, il est recommandé d'utiliser un plan réfléché du circuit.

2. Il est recommandé de remplacer C401 par un trimmer 6 pF en parallèle avec un condensateur céramique 5,6 ou 12 pF.
3. Changer la valeur de R238, R246, R338, R346 en 510 Ω et la valeur de R252, R257, R352, R357 en 120 Ω .
4. Changer la valeur de R242, R342 en 82 Ω .

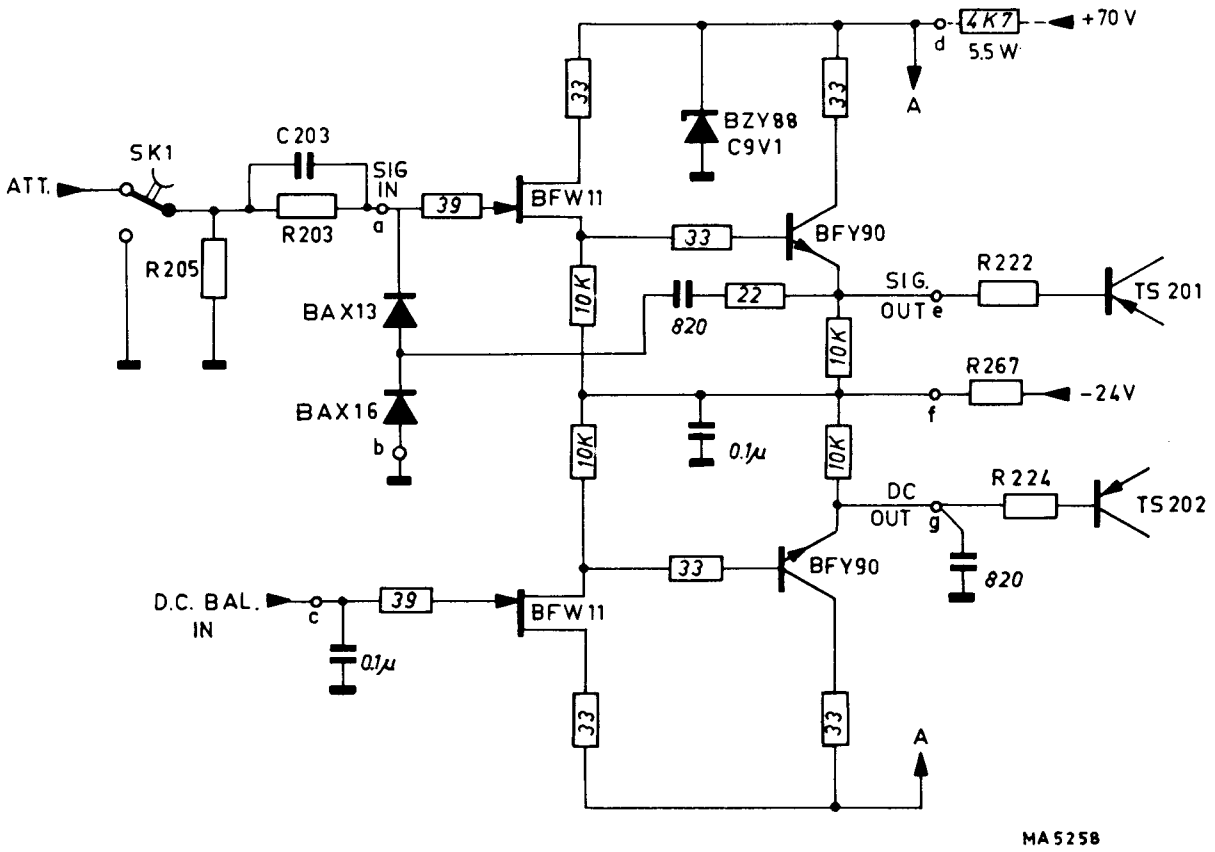
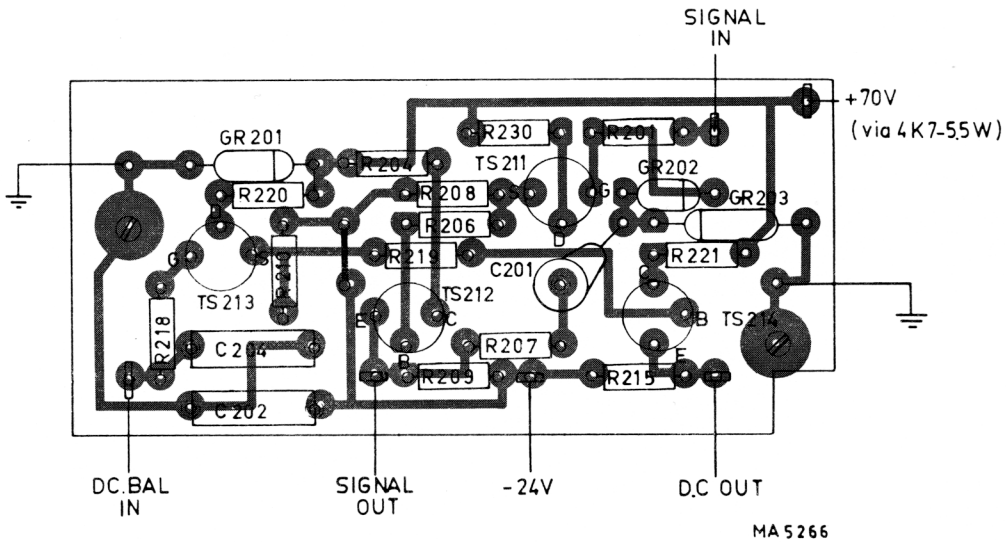

Fig. 1



Ordering code Channel A: 4822 216 50137
Channel B: 4822 216 50136

Fig. 2

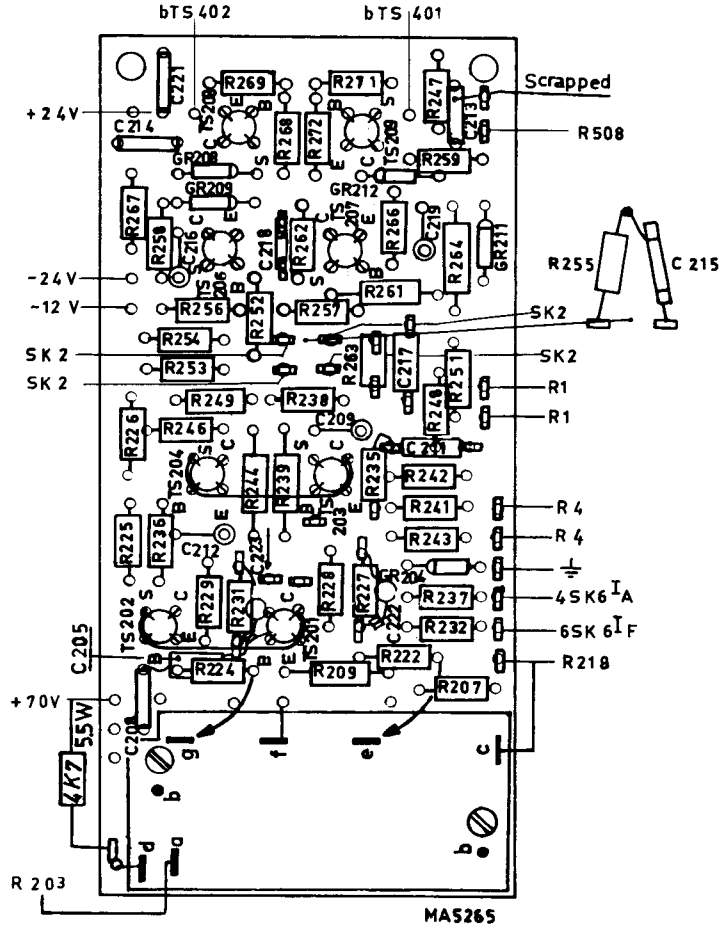
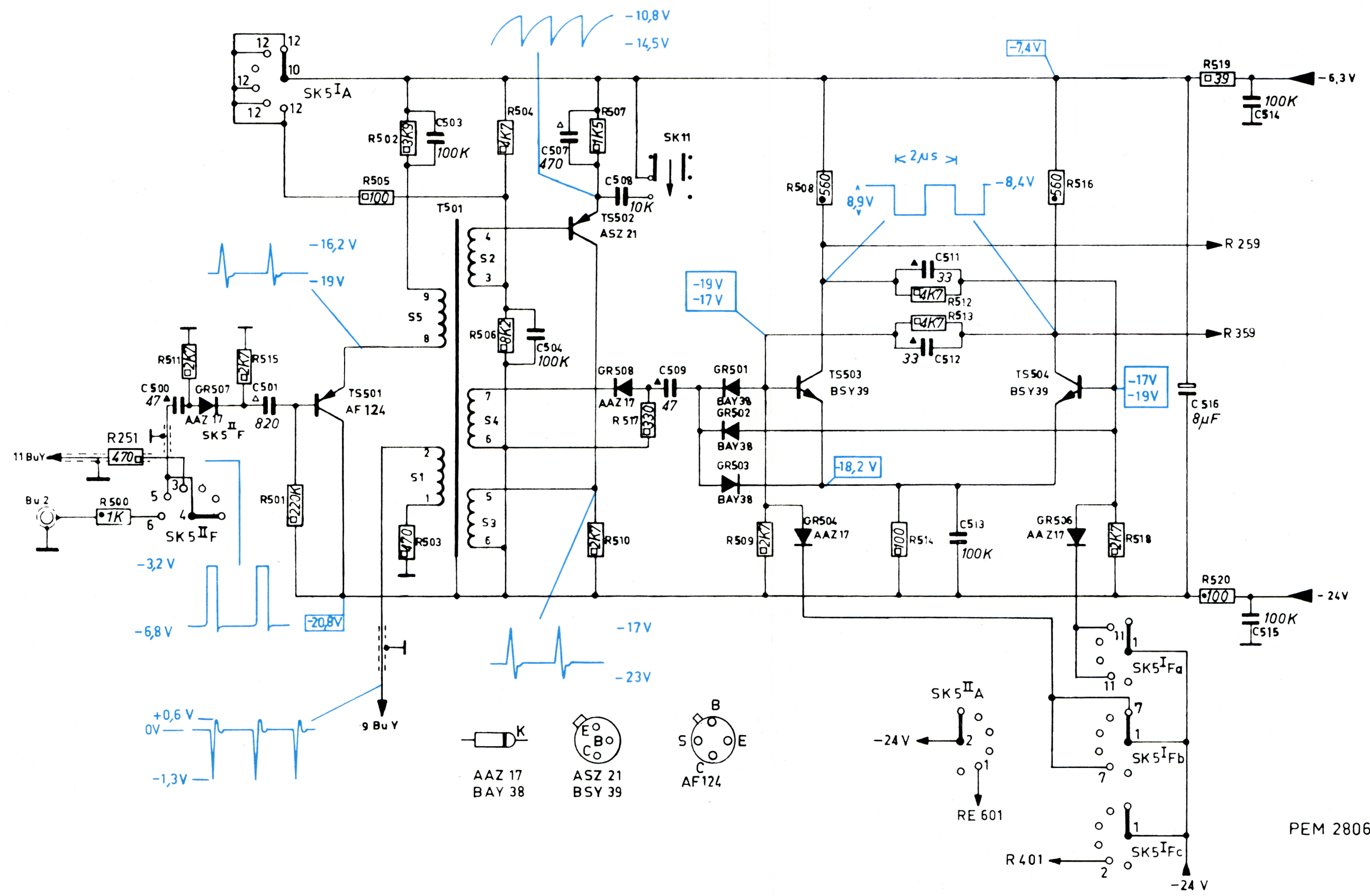

Fig. 3



PEM 2806 b

Fig. 20